

# **LIFESPAN**<sup>TM</sup>

**COMPOSITE ARCHITECTURAL BEAMS**

## **LIFESPAN BEAM TECHNICAL DATA SHEET**

VERSION D1.0 | 25/01/2023



Before installing, please ensure you have downloaded the latest version of this TDS by scanning this code.

[www.eva-last.com](http://www.eva-last.com)

A PRODUCT BY **EVA-LAST**<sup>®</sup>  
INSPIRED BY NATURE, DESIGNED FOR LIFE.

## Contents

Document guide .....	3
Material composition.....	5
Physical properties.....	6
Mechanical properties.....	7
Thermal properties.....	9
Weathering .....	10
Disclaimer and copyright.....	11
Appendix A .....	12
Appendix B .....	19

## Lifespan architectural beams

Lifespan architectural beams offer design versatility and increased span thanks to their specialised aluminium core that makes for easier installation at height. The outer coating of low-maintenance bamboo composite resists biodegradation, corrosion, and harsh weather, and offers built-in UV protection for beautiful durability. Enjoy the look of timber beams without the upkeep.

<b>Product name:</b>	Lifespan composite architectural beams
<b>Product use:</b>	Primarily used as an architectural beam in pergola structures and similar applications
<b>Material:</b>	Aluminium structure with composite cap
<b>Material description:</b>	An aluminium profile with Eva-tech cellulose-polymer cap

## Document guide

Eva-Last strives to evaluate their products in depth and present the technical and safety information available in a manner that assists with the application thereof. If additional data or information is required, please do not hesitate to contact us at [rad@eva-last.com](mailto:rad@eva-last.com).

In an attempt to simplify the information, similar data is loosely grouped into the categories summarised below. This document is ordered according to these categories and the applicable page number for the start of each section captured in the Table of Contents on page above.

- Material composition
- Physical properties
- Mechanical properties
- Thermal properties
- Fire reaction properties
- Weathering properties
- Surface properties

The material compositions section captures a summary of the product make-up from the Material Safety Data Sheet (MSDS). A link to the MSDS is provided for additional detail. Summaries of chemical compliance data available are also collected in this section.

The physical properties section provides a summary of available profiles and general material properties such as density, water absorption, etc. Additional profile information can be obtained from drawings in the appropriate appendix. Where possible, material properties that can be assigned to more specific categories are moved to the relevant section.

The mechanical properties section captures data related to the products reaction to various load conditions. The section is broadly assembled into the below categories. Additional profile and sectional information are captured by the drawings in the appropriate appendix.

- Material specific mechanical properties
- Profile specific mechanical properties
- Sectional properties

Product properties such as the expansion coefficient, thermal resistance, etc. are captured, where applicable, in the thermal properties section.

Information regarding the products reaction to fire is captured in the fire reaction properties section.

Test data relating to the acoustic performance of the product is summarised in the acoustic properties section.

Information on the products resistance to mold, termites, etc. is collected in the biodegradation properties section.

The surface properties section summarises information regarding the finish or texture of the product. Test data on aspects such as slip resistance (where applicable) is captured in this section.

Where the products form part of a system and, as a result, utilise other components, an additional section to capture useful data regarding these components has been added to this document.

Where information is not yet available, the section has been omitted. In the cases where information can be substituted or supplemented with alternative data (based on similar compositions, etc.) an attempt to do so is made. Where this is the case, it is highlighted. Please make use of the data accordingly. For any additional information regarding this, please feel free to contact [rad@eva-last.com](mailto:rad@eva-last.com).

Ensure the product and application thereof is suitable, rational, and compliant with any applicable regulations or standards. Wherever necessary, consult a suitably qualified professional. For information about the installation and use of the product, please see the applicable Installation Guide (IG). For additional material safety and handling information, please refer to the applicable MSDS. For any further information, please contact [rad@eva-last.com](mailto:rad@eva-last.com).

## Material composition

The following table is a simplified material composition for the Lifespan material technology. For more information regarding the composition, safety, and handling of the material, please see the **Lifespan MSDS**. To confirm which substances are compatible, or incompatible, with the product, please refer to **Appendix B**.

<b>Component</b>	<b>Substance</b>	<b>Mass</b>
Core	Aluminium alloy, 6063-T5	62%
	High density polyethylene (HDPE)	20%
Cap	Cellulose fibers (Bamboo or wood fibers)	11%
	Calcium carbonate	3%
Additional additives	Other	4%

\*Note material mass distribution may vary per profile.

## Physical properties

### General material properties

Typical properties of the Lifespan material technology are captured below as an indication of the expected behaviour of the aluminium and composite materials separately.

Properties	Results	Test method	Information
Core Density	2 700 kg/m <sup>3</sup>	ASTM D2395	Results are based on typical aluminium 6063-T5 materials.
Cap Density	1 250 kg/m <sup>3</sup>		Results are based on Eva-tech material.
Water absorption 180 h	Mass	1.85%	Gb/T17657-2013-4.6
	Length	-0.74%	
	Width	0.47%	GB/T17657-2013,GB/T24508-2009
	Height	1.29%	

### Profile properties

The following table is a summary of the currently available profiles, please see Appendix A for profile drawings.

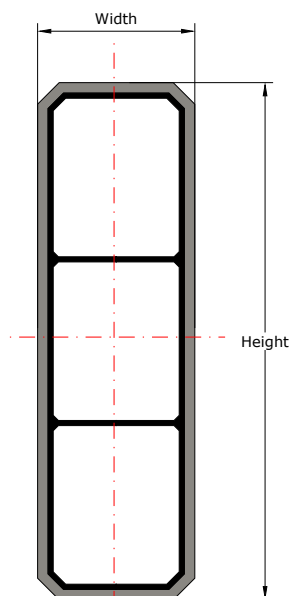

Profile ID	Profile width (mm)	Profile height (mm)	Mass per meter (kg/m)
STLS01X	30.5	100.5	1.3
STLS02	50.0	150.0	3.3
STLS09	30.0	50.0	0.8
STLS06	97.0	97.0	4.6
STLS07	150.0	150.0	8.1
STLS08	205.0	205.0	13.3

The mass provided are estimates and based on the density and area of the profile.

## Mechanical properties

### Material specific mechanical properties

#### Lifespan

All information within this table is currently based on internal laboratory results of Lifespan.

Property	Result	Test method standard	Information
<b>Shore hardness</b>	72		
<b>Scratch resistance</b>	8 N		
<b>Abrasion resistance</b>	0.049 g/100r	GB/T17657-2013,GB/T24508-2009	
<b>Impact resistance</b>	Pass		No cracking was visible.
<b>Surface bonding strength</b>	2.2 MPa		

#### Aluminium 6063 – T5





It is generally assumed that the aluminium skeleton of the Lifespan profiles provides the majority of resistance to any loads, and it is recommended that any design utilising these members adopts a similar approach. Below are typical material properties of aluminium 6063 – T5 (extracted from an online resource).

Property	Result	Information
<b>Modulus of elasticity (MOE)</b>	68.9 GPa	
<b>Poisson ratio</b>	0.33	
<b>Flexural strength</b>	145 MPa	Extracted from an online resource.
<b>Shear modulus</b>	25.8 GPa	
<b>Shear strength</b>	117 MPa	

### Profile flexural properties

Flexural properties of Lifespan can be influenced by the profile geometry and span. Typical properties of the Lifespan material technology are captured below based on internal and external test results as an indication of the expected behavior of specific Lifespan profiles.

Profile	Span (mm)	Ultimate Load (kN)	Modulus of rupture MOR (MPa)	Modulus of elasticity MOE (MPa)	Test method	Information
STLS01X		3.8	59.8	13.5		
STLS02	500 mm Horizontal	20.4	79.7	12.4		The listed profiles were tested internally.
STLS09		3.4	95.8	15.6		
STLS01X	500 mm Vertical	5.6	82.1	8.6	GN/T 17657-2013-4.7	The listed profiles were tested internally.
STLS02		Profile too tall to test internally				
STLS09		3.9	41.8	4.2		

Profile	Span (mm)	Yield strength (kN)	Ultimate failure load (kN)	Test method	Information	
STLS01	500 mm Horizontal 	6.1	8.2	ASTM 790 (modified)	The listed profiles were tested externally. This profile is not the same as STLS01X. And is provided for information only.	
	500 mm Vertical 	6.5	9.4			
STLS02	500 mm Horizontal 	16.8	22.9			The listed profiles were tested externally.
	500 mm Vertical 	9.4	17.5			



### Sectional properties

The following table provides a sectional property summary of the currently available Lifespan profiles in their typical board orientation. The sectional properties do not include the cap as it is generally assumed that the aluminium skeleton of the Lifespan profiles provides the majority of resistance to any loads. Please see **Appendix A** for profile drawings and further information.

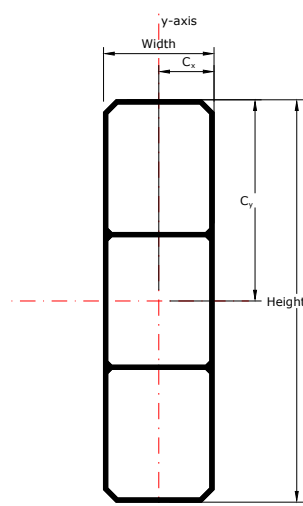

Profile ID	Application	Profile details			Moments of inertia		Centroid		Elastic sectional modulus	
		Width (mm)	Thickness (mm)	Area (mm <sup>2</sup> )	I <sub>x</sub> (mm <sup>4</sup> )	I <sub>y</sub> (mm <sup>4</sup> )	C <sub>x</sub> (mm)	C <sub>y</sub> (mm)	S <sub>x</sub> (mm <sup>3</sup> )	S <sub>y</sub> (mm <sup>3</sup> )
STLS01X	Beam	26.5	96.5	288.7	259 885	35 682	13.3	48.3	5 386	2 693
STLS02	Beam	45.0	145.0	761.6	1 578 215	252 817	22.5	72.5	21 768	11 236
STLS09	Beam	26.0	46.0	1 446.4	1 513 294	1 513 294	47.0	47.0	32 232	32 232
STLS07	Post	93.9	93.9	2 304.0	6 530 505	6 530 505	73.0	73.0	89 459	89 459
STLS08	Post	146.0	146.0	5 563.8	32 796 272	32 796 272	102.4	102.4	320 433	320 433
STLS06	Post	199.7	199.7	166.0	40 492	18 090	12.9	23.0	1 761	1 397

## Thermal properties

Typical properties of the Lifespan material technology and the aluminium core are captured below as an indication of the expected behaviour of the Lifespan material.

Properties	Results	Test method	Information
Aluminium Coefficient of Thermal Expansion (CTE)	$23.4 \times 10^{-6}$ mm/mm.°C	ASTM D696-16	Results are based on internal testing of Lifespan beams with aluminium 6063-T5 materials.
Thermal conductivity of aluminium at 25 °C	209 W/m.K		Extracted from online sources.

## Fire reaction properties

Results currently unavailable.

## Weathering

The environment to which materials are exposed influences how quickly the material will weather (or deteriorate). This includes degradation factors like UV exposure, oxidation or contact with organisms within the environment such as termites or mold.

### Colour fade

Materials are susceptible to colour change over time due to weathering.  $\Delta E$  denotes the colour difference between an original sample and a tested sample after exposure to UV light.  $\Delta E$  is measured on a scale of 1 to 100 and provides a metric to understand how the human eye perceives colour change.

As Lifespan caps are made from Eva-tech materials, the following external laboratory of Eva-tech boards, have been provided.

Standard	Hours	Colour	$\Delta E$	Test method	Information
ASTM	1 300	Rusteak , Brown (C04)	8.24	ASTM G154	Changes perceptible at a glance.
		Xavia, Grey (C11)	4.30		Changes perceptible through close observation.

## Disclaimer and copyright

### Document disclaimer

The provided information is offered in good faith as accurate but without guarantee. Eva-Last makes no warranties or representations of any kind (express or implied) about the accuracy, adequacy, currency, or completeness of the information, or that it is necessarily suitable for the intended use.

Compliance with this document does not guarantee immunity from breach of any statutory requirements, building codes or relevant standards. The final responsibility for the correct design and specification rests with the designer and, for its satisfactory execution, with the contractor. Appropriate warnings and safe handling procedures should be provided to handlers and users.

While most data have been compiled from research, case histories, experience and testing, small changes in the environment can produce marked differences in performance. The decision to use a material, and in what manner, is made at your own risk. The use of a material and method may therefore need to be modified to its intended end use and environment.

Eva-Last, its directors, officers or employees shall not be responsible for any direct, indirect, or special loss or damage arising from, or as a consequence of, use of, or reliance upon, any information contained in this document or other documents referenced herein. Eva-Last expressly disclaims any liability which is based on or arises out of the information or any errors, omissions or misstatements herein.

### Drawing disclaimer

All dimensions and specifications are offered in good faith as accurate but without guarantee. The information captured herein may not contain complete details. Eva-Last makes no warranties or representations of any kind (express or implied) about the accuracy, adequacy, currency, or completeness of the information, or that it is necessarily suitable for the intended use.

Compliance with this document does not guarantee immunity from breach of any statutory requirements, building codes or relevant standards. The final responsibility for the correct design and specification rests with the designer and, for its satisfactory execution, with the contractor.

### Utilisation disclaimer

Legislation may differ between jurisdictions. Before installing any Eva-Last product, ensure that the application is rational and complies with the local regulations and building codes. Wherever necessary, consult a suitably qualified professional. Be sure to comply with material manufacturer specifications. Where manufacturers and building codes differ, revert to the building code requirements. Check that your choice of product is suitable for its intended application. For further product specification and information visit [www.eva-last.com](http://www.eva-last.com).

### Copyright

If reprinted or reproduced or utilised in any form Eva-Last should be acknowledged as the source of the information.

Eva-Last periodically updates the information contained in this document as well as that of the Eva Last documents that have been referenced herein. Before using this document, please refer to the Eva-Last website ([www.eva-last.com](http://www.eva-last.com)) for the most up-to-date documents.

### Contact information

Eva-Last

Room 1203, 12/F Tower 333 Canton Road, Tsimshatsui, Hong Kong, China

**Emergency Contact:** +86 021 53397986

**Product information:** +27 10 593 9220

**Email:** [info@eva-last.com](mailto:info@eva-last.com)

**Website:** [www.eva-last.com](http://www.eva-last.com)

## **Appendix A**

### Profiles details

PROFILE PROPERTIES	ALUMINIUM CORE	COMPOSITE CAP
AREA (mm <sup>2</sup> )	166	304
APPROXIMATE MASS (kg/m)	0.8	



Composite cap

Aluminium core

SECTION PROPERTIES		
$I_x$ (mm <sup>4</sup> )		40 492
$I_y$ (mm <sup>4</sup> )		18 090
$r_x$ (mm)		15.6
$r_y$ (mm)		10.4
$C_x$ (mm)		12.9
$C_y$ (mm)		23.0
$S_x$ (mm <sup>3</sup> )		1 761
$S_y$ (mm <sup>3</sup> )		1 397

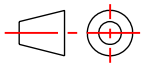

DRAWING TITLE  
Lifespan - Architectural beams - For TDS - STLS01x

FILE NAME  
Lifespan - Architectural beams - For TDS

DRAWING NUMBER  
220620CLS09BPD

REV  
C2.4

DATE  
2022-06-20

SCALE  
1:1

PAGE  
A4

UNLESS OTHERWISE SPECIFIED DIMENSIONS ARE IN MILLIMETERS

ISSUED FOR INFORMATION

**LIFESPAN**<sup>TM</sup>  
COMPOSITE ARCHITECTURAL BEAMS

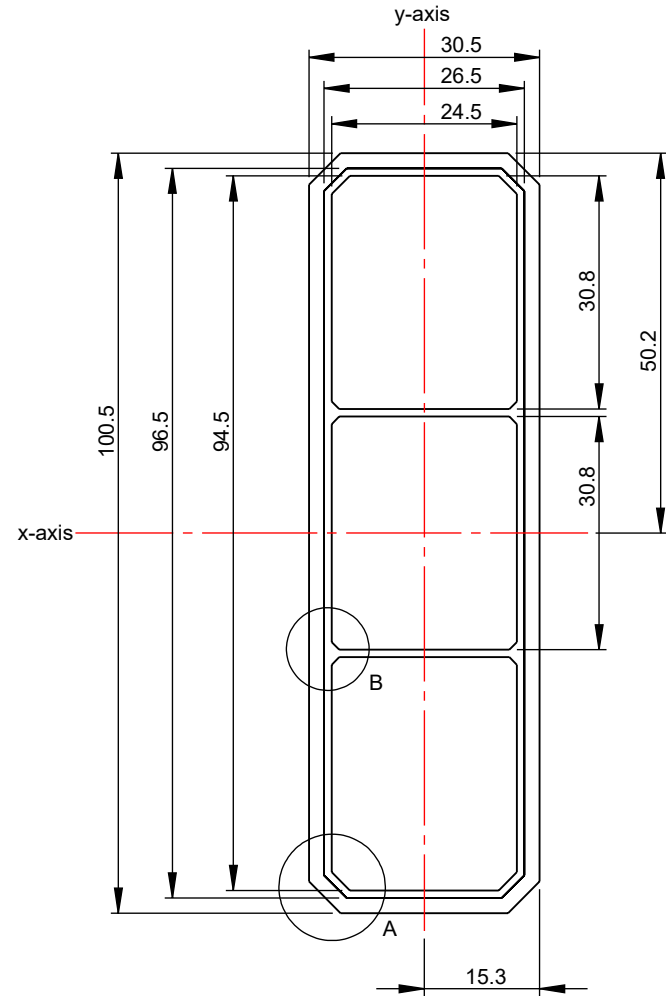

Lifespan profile - STLS01x  
SCALE 1:1

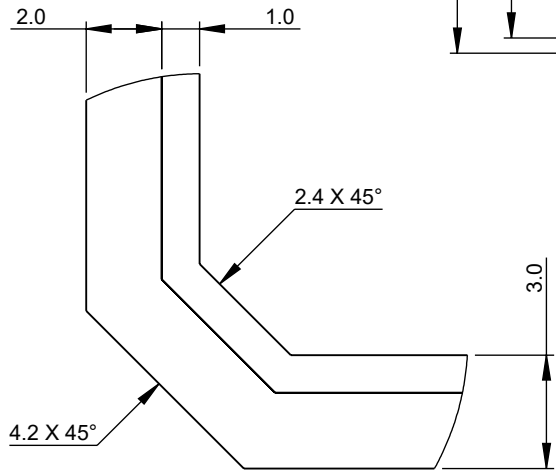

DETAIL A  
SCALE 5 : 1

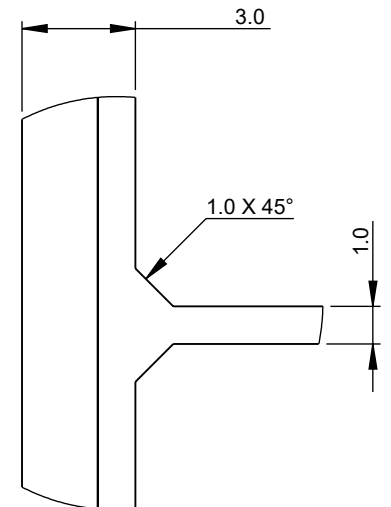

DETAIL B  
SCALE 5 : 1

PROFILE PROPERTIES	ALUMINIUM CORE	COMPOSITE CAP
AREA (mm <sup>2</sup> )	762	975
APPROXIMATE MASS (kg/m)	3.30	



SECTION PROPERTIES		
$I_x$ (mm <sup>4</sup> )		1 578 215
$I_y$ (mm <sup>4</sup> )		252 817
$r_x$ (mm)		45.5
$r_y$ (mm)		18.2
$C_x$ (mm)		22.5
$C_y$ (mm)		72.5
$S_x$ (mm <sup>3</sup> )		21 768
$S_y$ (mm <sup>3</sup> )		11 236

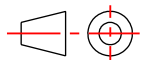

DRAWING TITLE  
Lifespan - Architectural beams - For TDS - STLS02

FILE NAME  
Lifespan - Architectural beams - For TDS

DRAWING NUMBER  
220620CLS09BPD

REV  
C2.4

DATE  
2022-06-20

SCALE  
1:1

PAGE  
A4

UNLESS OTHERWISE SPECIFIED DIMENSIONS ARE IN MILLIMETERS  
ISSUED FOR INFORMATION

**LIFESPAN**<sup>TM</sup>  
COMPOSITE ARCHITECTURAL BEAMS

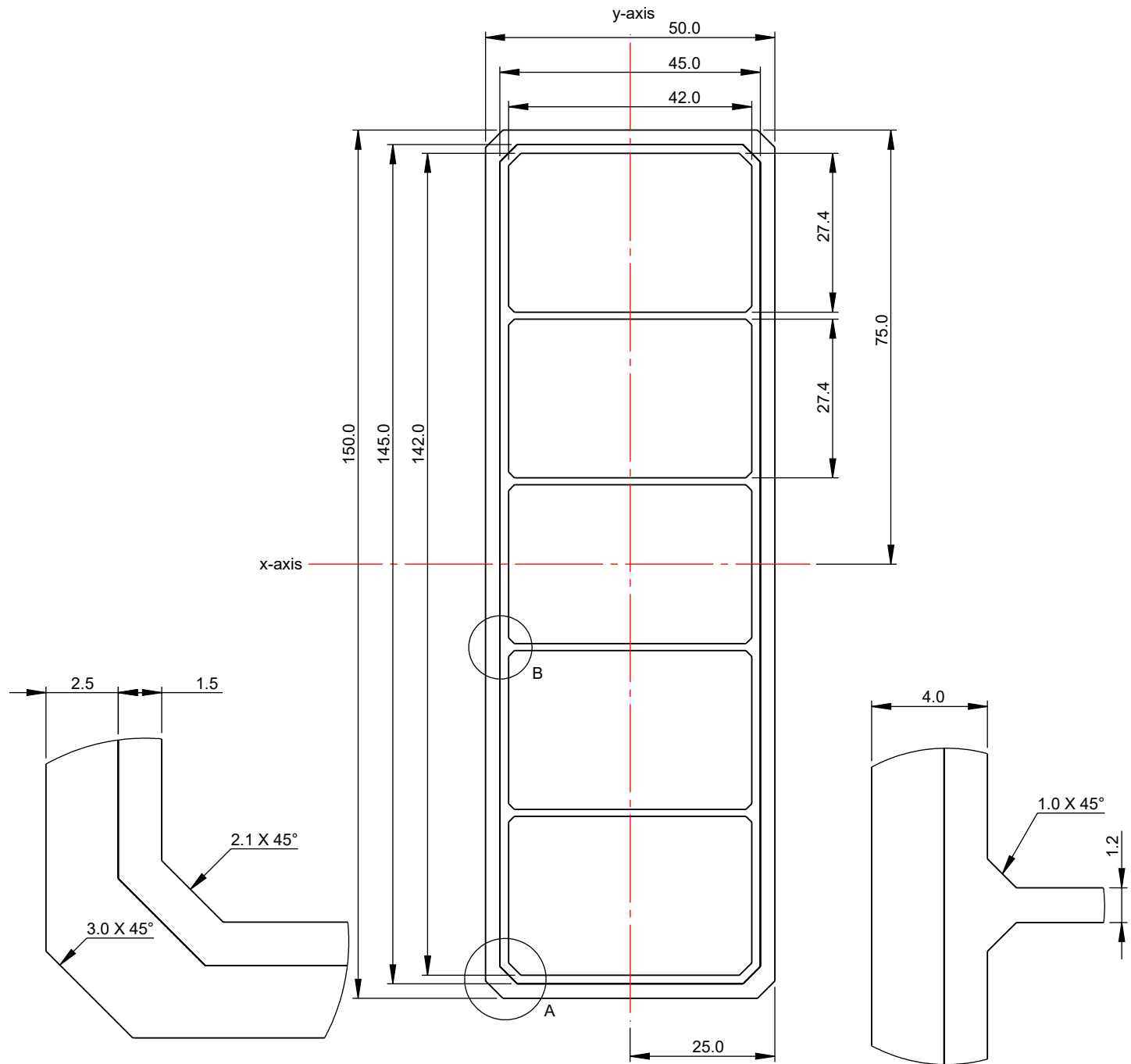

DETAIL A  
SCALE 5 : 1

Lifespan profile - STLS02  
SCALE 1:1

DETAIL B  
SCALE 5 : 1

PROFILE PROPERTIES	ALUMINIUM CORE	COMPOSITE CAP
AREA (mm <sup>2</sup> )	1 471	561
APPROXIMATE MASS (kg/m)	4.6	



SECTION PROPERTIES	
$I_x$ (mm <sup>4</sup> )	1 513 294
$I_y$ (mm <sup>4</sup> )	1 513 294
$r_x$ (mm)	32.4
$r_y$ (mm)	32.4
$C_x$ (mm)	47.0
$C_y$ (mm)	47.0
$S_x$ (mm <sup>3</sup> )	32 232
$S_y$ (mm <sup>3</sup> )	32 232

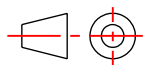

DRAWING TITLE  
Lifespan - Architectural beams - For TDS - STLS06

FILE NAME  
Lifespan - Architectural beams - For TDS

DRAWING NUMBER 220620CLS09BPD	REV C2.4
----------------------------------	-------------

DATE 2022-06-20	SCALE 1:1	PAGE A4
--------------------	--------------	------------

UNLESS OTHERWISE SPECIFIED DIMENSIONS ARE IN MILLIMETERS  
ISSUED FOR INFORMATION

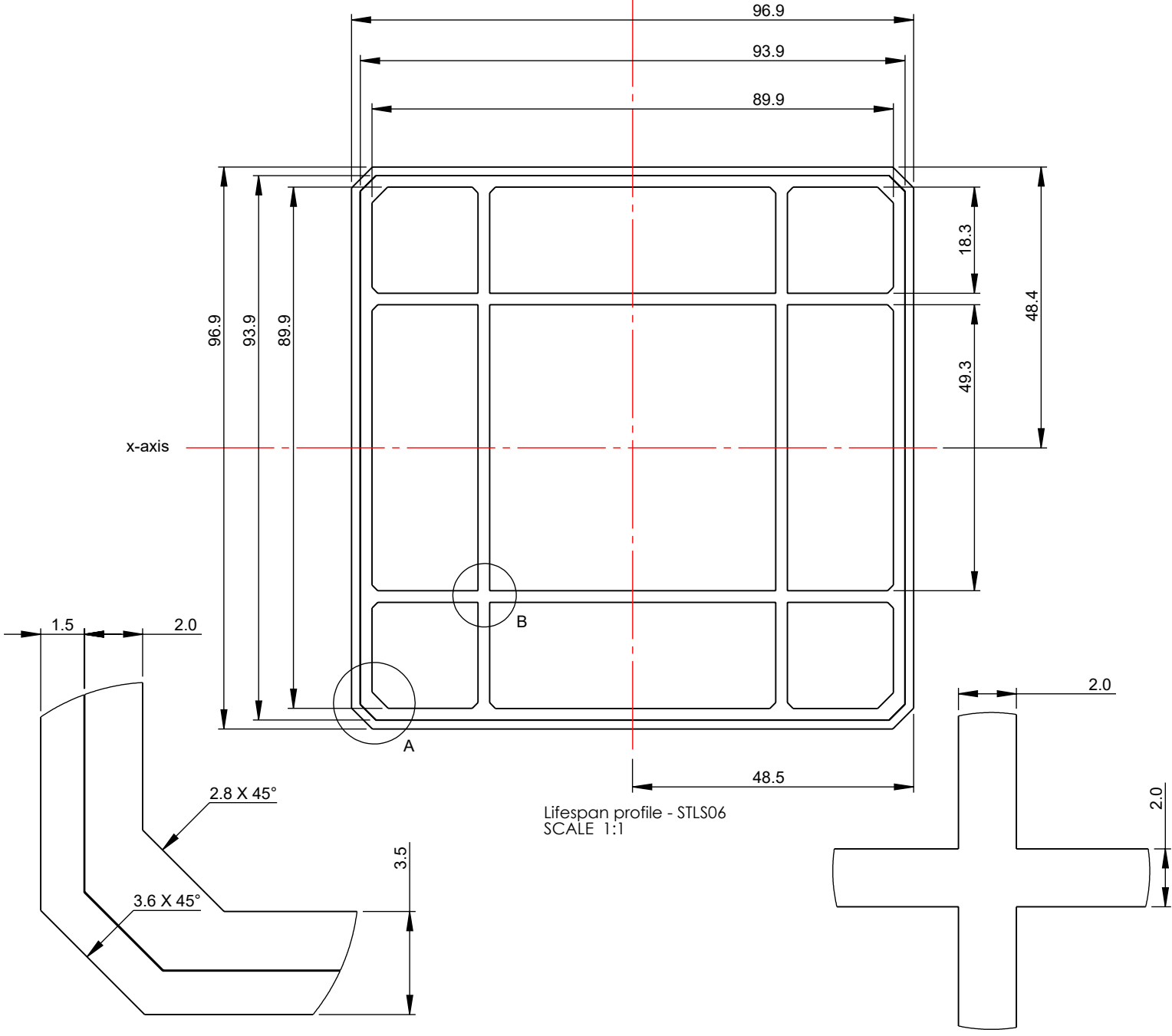

DETAIL A  
SCALE 5 : 1

DETAIL B  
SCALE 5 : 1



PROFILE PROPERTIES	ALUMINIUM CORE	COMPOSITE CAP
AREA (mm <sup>2</sup> )	2 304	1 184
APPROXIMATE MASS (kg/m)	8.1	



SECTION PROPERTIES	
$I_x$ (mm <sup>4</sup> )	6 530 505
$I_y$ (mm <sup>4</sup> )	6 530 505
$r_x$ (mm)	53.2
$r_y$ (mm)	53.2
$C_x$ (mm)	75.0
$C_y$ (mm)	75.0
$S_x$ (mm <sup>3</sup> )	89 459
$S_y$ (mm <sup>3</sup> )	89 459

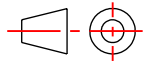

DRAWING TITLE		
Lifespan - Architectural beams - For TDS - STLS07		
FILE NAME		
Lifespan - Architectural beams - For TDS		
DRAWING NUMBER		REV
220620CLS09BPD		C2.4
DATE	SCALE	PAGE
2022-06-20	1:1	A4

UNLESS OTHERWISE SPECIFIED DIMENSIONS ARE IN MILLIMETERS  
ISSUED FOR INFORMATION

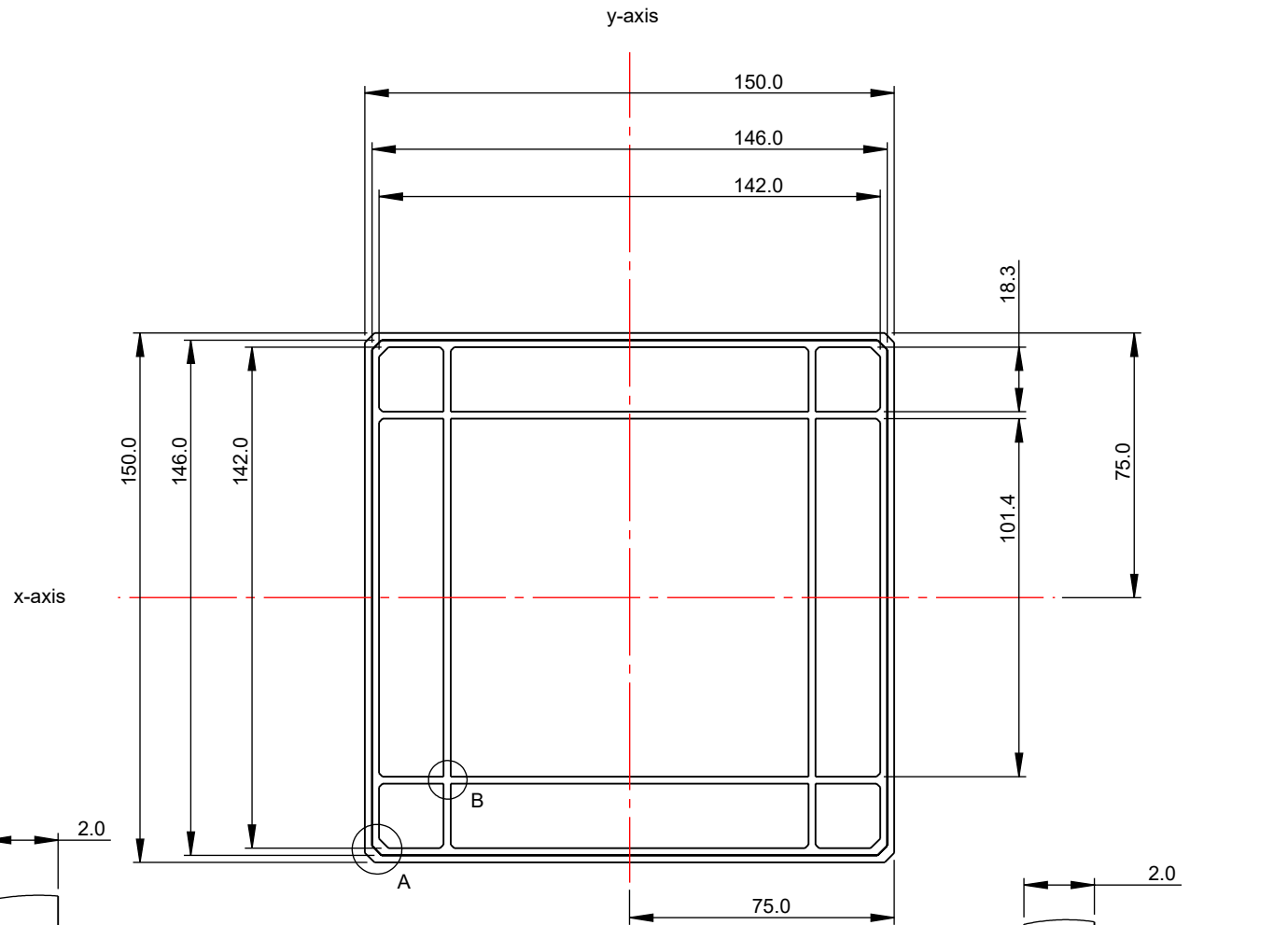

Lifespan profile - STLS07  
SCALE 1:2

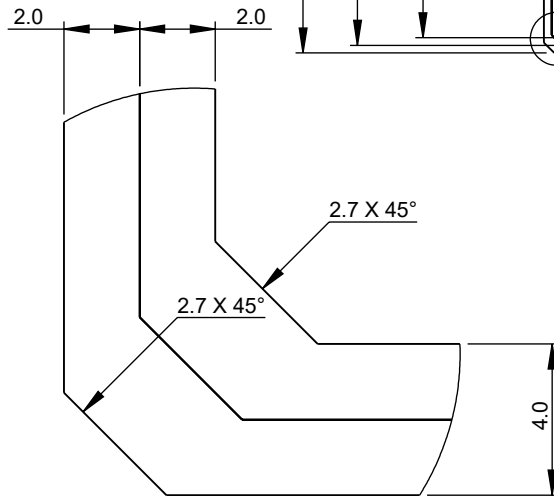

DETAIL A  
SCALE 5 : 1

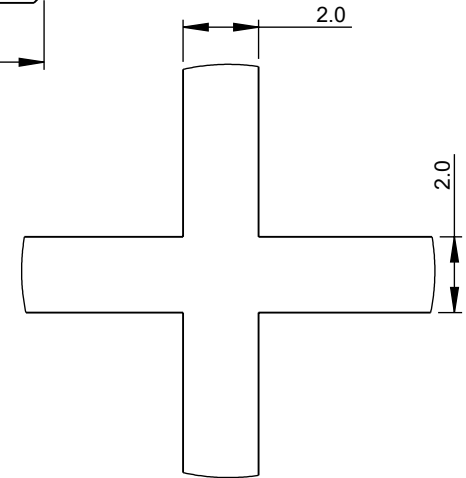

DETAIL B  
SCALE 5 : 1

PROFILE PROPERTIES	ALUMINIUM CORE	COMPOSITE CAP
AREA (mm <sup>2</sup> )	4 223	1 747
APPROXIMATE MASS (kg/m)	13.3	



SECTION PROPERTIES		
$I_x$ (mm <sup>4</sup> )		35 640 529
$I_y$ (mm <sup>4</sup> )		35 640 529
$r_x$ (mm)		91.9
$r_y$ (mm)		91.9
$C_x$ (mm)		102.4
$C_y$ (mm)		102.4
$S_x$ (mm <sup>3</sup> )		355 162
$S_y$ (mm <sup>3</sup> )		355 162

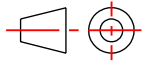

DRAWING TITLE  
Lifespan - Architectural beams - For TDS - STLS08

FILE NAME  
Lifespan - Architectural beams - For TDS

DRAWING NUMBER  
220620CLS09BPD

REV  
C2.4

DATE  
2022-06-20

SCALE  
1:1

PAGE  
A4

UNLESS OTHERWISE SPECIFIED DIMENSIONS ARE IN MILLIMETERS

ISSUED FOR INFORMATION

**LIFESPAN**<sup>TM</sup>  
COMPOSITE ARCHITECTURAL BEAMS

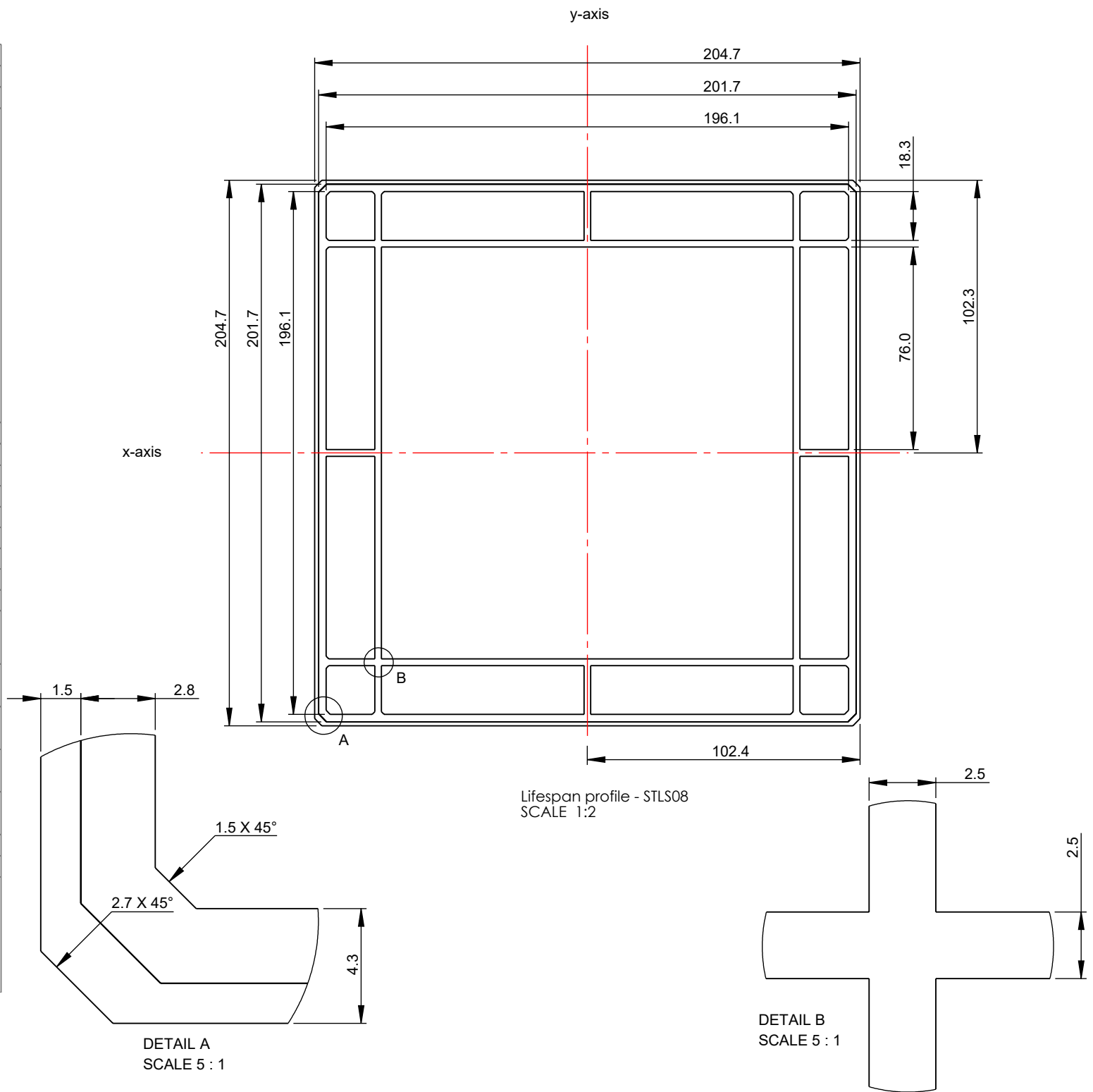

PROFILE PROPERTIES	ALUMINIUM CORE	COMPOSITE CAP
AREA (mm <sup>2</sup> )	166	304
APPROXIMATE MASS (kg/m)	0.8	

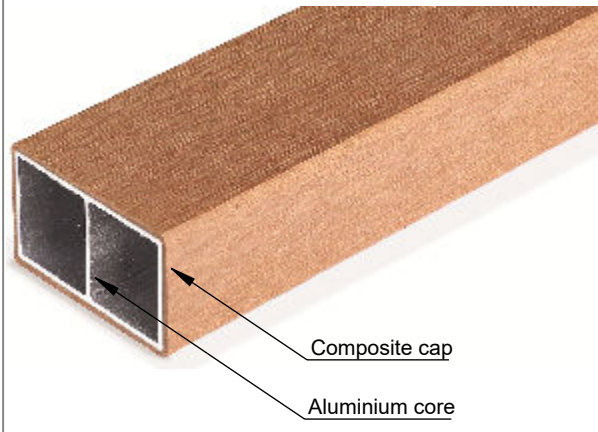

SECTION PROPERTIES		
$I_x$ (mm <sup>4</sup> )		40 492
$I_y$ (mm <sup>4</sup> )		18 090
$r_x$ (mm)		15.6
$r_y$ (mm)		10.4
$C_x$ (mm)		12.9
$C_y$ (mm)		23.0
$S_x$ (mm <sup>3</sup> )		1 761
$S_y$ (mm <sup>3</sup> )		1 397

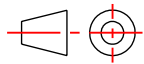

DRAWING TITLE		
Lifespan - Architectural beam - STLS09		
FILE NAME		
Lifespan - Architectural beams - For TDS		
DRAWING NUMBER		REV
220620CLS09BPD		C2.4
DATE	SCALE	PAGE
2022-06-20	1:1	A4

UNLESS OTHERWISE SPECIFIED DIMENSIONS ARE IN MILLIMETERS  
ISSUED FOR INFORMATION

**LIFESPAN**<sup>TM</sup>  
COMPOSITE ARCHITECTURAL BEAMS

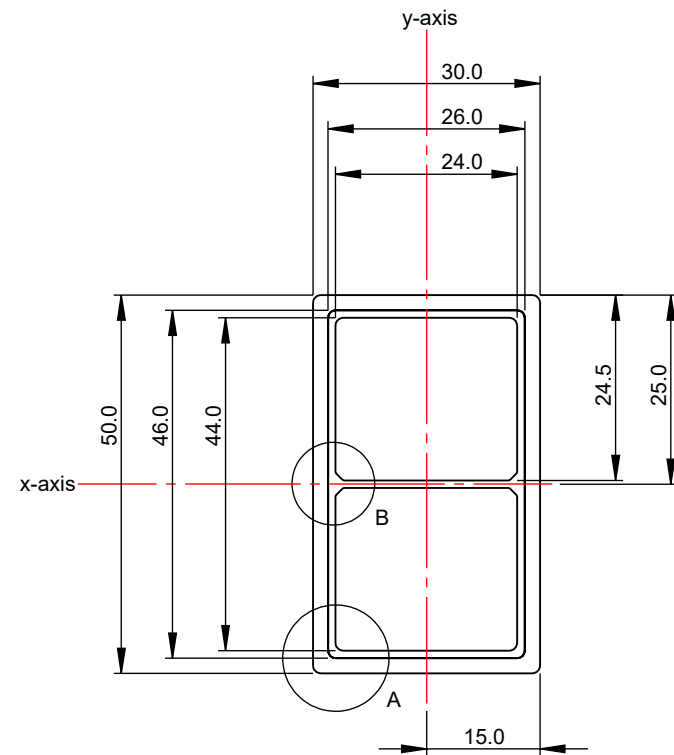

Lifespan profile - STLS09  
SCALE 1:1

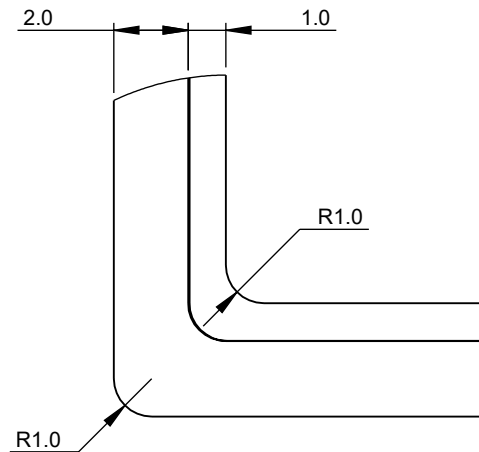

DETAIL A  
SCALE 5:1

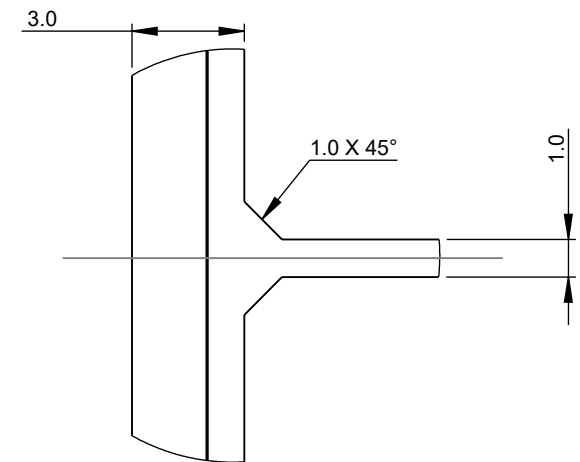

DETAIL B  
SCALE 5:1

## **Appendix B**

### **Material compatibility**

The following information provides an extensive list of substances that may negatively impact the Polyethylene material within the cap of lifespan. This does not account for the cellulose material within the composition of the cap. Please contact [rad@eva-last.com](mailto:rad@eva-last.com) for further information.

The table provided is referenced from the online sources BASF and is provided for ease of information.

It is important to check material compatibility when choosing chemicals that the product may encounter, as they may prematurely degrade the product, these may include ingredients in cleaning products, pool additives and even oils and saps from local vegetation.

**CODES**

- + = Resistant no indication that serviceability would be impaired.
- o = Variable resistance, depending on conditions of use.
- = Unresistant, not recommended for service applications under any conditions.

**“REAGENT” + # Plasticizer.**

Certain types of chemicals are absorbed to varying degrees by poly-ethylene causing swelling, weight-gain, softening and some loss of yield strength. These plasticizing materials cause no actual chemical degradation of the resin. Several of these chemicals have a strong plasticizing effect (e.g. aromatic hydrocarbons benzene), whereas others have weaker effects (e.g. gasoline). Certain plasticizers are sufficiently volatile that if they are removed from contact with the polyethylene, the part will “dry” out and return to its original condition with no loss of properties.

**“REAGENT”+ = Oxidizers.**

Oxidizers are the only group of materials capable of chemically degrading polyethylene. The effects on the poly-ethylene may be gradual even for strong oxidizers and short-term effects may not be measurable. However, if continuous long-term exposure is intended, the chemical effects should be checked regularly.

REAGENT	CONCENTRATION	HDPE	
		70°	140°
Acetone		o	-
Acetaldehyde*	100%	o	-
Acetic Acid*	10%	+	+
Acetic Acid*	60%	+	o
Acetic Anhydride*		-	-
Air		+	+
Aluminium Chloride	all conc	+	+
Aluminium Fluoride	all conc	+	+
Aluminium Sulphate	all conc	+	+

Alums	all types	+	+
Ammonia	100% dry gas	+	+
Ammonium Carbonate		+	+
Ammonium Chloride	sat'd	+	+
Ammonium Fluoride	sat'd	+	+
Ammonium Hydroxide	10%	+	+
Ammonium Hydroxide	28%	+	+
Ammonium Nitrate	sat'd	+	+
Ammonium Persulphate	sat'd	+	+
Ammonium Sulphate	sat'd	+	+
Ammonium Metaphosphate	sat'd	+	+
Ammonium Sulphide	sat'd	+	+
Amyl Acetate#*	100%	-	-
Amyl Alcohol#*	100%	+	+
Amyl Chloride#	100%	-	-
Aniline#*	100%	-	o
Aqua Regia+		-	-
Arsenic Acid	all conc	+	+
Aromatic Hydrocarbons#*		-	-
Ascorbic Acid	10%	+	+
Barium Carbonate	sat'd	+	+
Barium Chloride	sat'd	+	+
Barium Hydroxide		+	+
Barium Sulphate	sat'd	+	+
Barium Sulphide	sat'd	+	+
Beer		+	+
Benzene#*		-	-
Benzoic Acid	all conc	+	+
Bismuth Carbonate	sat'd	+	+
Bleach Lye	10%	+	+
Borax	sat'd	+	+
Boric Acid	all conc	+	+
Boron Trifluoride		+	+
Brine		+	+
Bromine+	liquid	-	-
Bromine Water#	sat'd	-	-
Butanediol*	10%	+	+
Butanediol*	60%	+	+
Butanediol*	100%	+	+
Butter*		+	+
n-Butyl Acetate#*	100%	+	o
n-Butyl Alcohol*	100%	+	+
Butyric Acid#	conc	-	-
Calcium Bisulphite		+	+
Calcium Carbonate	sat'd	+	+
Calcium Chlorate	sat'd	+	+
Calcium Chloride	sat'd	+	+
Calcium Hydroxide	conc	+	+

Calcium Hypochlorite	bleach sol	+	+
Calcium Nitrate	50%	+	+
Calcium Oxide	sat'd	+	+
Calcium Sulphate		+	+
Camphor Oil#*		o	-
Carbon Dioxide	all conc	+	+
Carbon Disulphide		-	-
Carbon Monoxide		+	+
Carbon Tetrachloride#		o	-
Carbonic Acid		+	+
Castor Oil*	conc	+	+
Chlorine+	100% dry gas	-	-
Chlorine Liquid+		-	-
Chlorine Water+	2% sat'd sol	+	+
Chlorobenzene#*		-	-
Chloroform#*		o	-
Chlorosulphonic Acid	100%	-	-
Chrome Alum	sat'd	+	+
Chromic Acid	80%	-	-
Chromic Acid	50%	+	o
Chromic Acid	10%	+	+
Cider*		+	+
Citric Acid*	sat'd	+	+
Coconut Oil Alcohols*		+	+
Coffee		+	+
Cola Concentrate*		+	+
Copper Chloride	sat'd	+	+
Copper Cyanide	sat'd	+	+
Copper Fluoride	2%	+	+
Copper Nitrate	sat'd	+	+
Copper Sulphate	sat'd	+	+
Corn Oil*		+	+
Cottonseed Oil*		+	+
Cuprous Chloride	sat'd	+	+
Detergents Synthetic*		+	+
Developers Photographic		+	+
Dextrin	sat'd	+	+
Dextrose	sat'd	+	+
Diazo Salts		+	+
Dibutylphthalate*		o	o
Dichlorobenzene#*		-	-
Diethyl Ketone#*		o	o
Diethylene Glycol*		+	+
Diglycolic Acid*		+	+
Dimethylamine		-	-
Disodium Phosphate		o	+
Emulsions, Photographic*		+	+
Ethyl Acetate##* 100%	100%	o	-

Ethyl Alcohol* 100%	100%	+	+
Ethyl Alcohol* 35%	35%	+	+
Ethyl Benzene#*		-	-
Ethyl Chloride#		-	-
Ethyl Ether#		-	-
Ethylene Chloride#*		-	-
Ethylene Glycol*		+	+
Fatty Acids*		+	+
Ferric Chloride sat'd	sat'd	+	+
Ferric Nitrate sat'd	sat'd	+	+
Ferrous Chloride sat'd	sat'd	+	+
Ferrous Sulphate		+	+
Fish Solubles*		+	+
Fluoboric Acid		+	+
Fluosillic Acid conc	conc	+	o
Fluosillic Acid 32%	32%	+	+
Formic Acid all conc	all conc	+	+
Fructose sat'd	d	+	+
Fruit Pulp*		+	+
Furtural# 100%	100%	o	-
Furturyl Alcohol#*		o	-
Gallic Acid* sat'd		+	+
Gasoline#*		o	o
Glucose		+	+
Glycerine*		+	+
Glycol*		+	+
Glycolic Acid* 30%	30%	+	+
Grape Sugar		+	+
n-Heptane#*		o	o
Hexachlorobenzene		+	-
Hexanol Tertiary*		+	+
Hydrobromic Acid 50%	50%	+	+
Hydrochloric Acid all conc	all conc	+	+
Hydrocyanic Acid sat'd	sat'd	+	+
Hydrofluoric Acid* 60%	60%	+	+
Hydrogen 100%		+	+
Hydrogen Chloride dry gas	dry gas	+	+
Hydrogen Peroxide 30%	30%	+	+
Hydrogen Peroxide 10%	10%	+	+
Hydrogen Sulphide		+	+
Hydroquinone		+	+
Hypochlorous Acid conc.	conc.	+	+
Inks*		+	+
Iodine+ in KI sol'n	in KIsol'd	o	-
Isopropyl Alcohol 100%	100%	-	-
Lead Acetate sat'd	sat'd	+	+
Lead Nitrate		+	+
Lactic Acid* 20%	20%	+	+

Linseed Oil* 100%	100%	o	-
Magnesium Carbonate	sat'd	+	+
Magnesium Chloride	sat'd	+	+
Magnesium Hydroxide	sat'd	+	+
Magnesium Nitrate	sat'd	+	+
Magnesium Sulphate	sat'd	+	+
Mercuric Chloride	40%	+	+
Mercuric Cyanide	sat'd	+	+
Mercury		+	+
Methyl Alcohol*	100%	+	+
Methylethyl Ketone#*	100%	o	-
Methylene Chloride#*	100%	o	o
Milk		+	+
Mineral Oils#		o	-
Molasses		+	+
Naphtha#*		o	-
Naphthalene#*		o	-
Nickel Chloride	conc	+	+
Nickel Nitrate	sat'd	+	+
Nickel Sulphate	conc	+	+
Nicotine*	dilute	+	+
Nitric Acid	0-30%	+	+
Nitric Acid+	30-50%	+	o
Nitric Acid+	70%	+	o
Nitric Acid+	95-98%	-	-
Nitrobenzene#*	100%	-	-
n-Octane		+	+
Oleic Acid		o	-
Oxalic Acid*	sat'd	+	+
Perchloroethylene#		-	-
Phosphoric Acid	95%	+	+
Photographic Solutions		+	+
Plating Solutions*			
Brass		+	+
Cadmium		+	+
Chromium		+	+
Copper		+	+
Gold		+	+
Indium		+	+
Lead		+	+
Nickel		+	+
Rhodium		+	+
Sliver		+	+
Tin		+	+
Zinc		+	+
Potassium Bicarbonate	sat'd	+	+
Potassium Bromide	sat'd	+	+
Potassium Bromate	10%	+	+

Potassium Carbonate		+	+
Potassium Chlorate	sat'd	+	+
Potassium Chloride	sat'd	+	+
Potassium Chromate	40%	+	+
Potassium Cyanide	sat'd	+	+
Potassium Dichromate	40%	+	+
Potassium Ferri/Ferro	Ferro		
Cyanide	sat'd	+	+
Potassium Fluoride		+	+
Potassium Hydroxide	conc	+	+
Potassium Nitrate	sat'd	+	+
Potassium Perborate	sat'd	+	+
Potassium Perchlorate	10%	+	+
Potassium Permanganate	20%	+	+
Potassium Persulphate	sat'd	+	+
Potassium Sulphate	conc	+	+
Potassium Sulphide	conc	+	+
Potassium Sulphite 100%	conc	+	+
Propargyl Alcohol*		+	+
n-Propyl Alcohol*		+	+
Propylene Dichloride#*		-	-
Propylene GlyCol*	sat'd	+	+
Pyridine*		+	-
Resorcinol		+	+
Salicylic Acid	sat'd	+	+
Sea Water		+	+
Selenic Acid Shortening*	any conc	+	+
Sliver Nitrate Sol'n		+	+
Soap Solutions*	any conc	+	+
Sodium Acetate	sat'd	+	+
Sodium Benzoate	35%	+	+
Sodium Biscarbonate	sat'd	+	+
Sodium Bisulphate	sat'd	+	+
Sodium Bisulphite	sat'd	+	+
Sodium Borate	dilute	+	+
Sodium Bromide	dilute	+	+
Sodium Carbonate	conc	+	+
Sodium Chlorate	sat'd	+	+
Sodium Chloride	sat'd	+	+
Sodium Cyanide	sat'd	+	+
Sodium Dichromate	sat'd	+	+
Sodium Ferri/Ferro	sat'd	+	+
Cyanide	sat'd	+	+
Sodium Fluoride	sat'd	+	+
Sodium Hydroxide	conc	+	+
Sodium Hypochlorite	sat'd	+	+
Sodium Nitrate		+	+

Sodium Sulphate	+	+
Sodium Sulphide	+	+
Sodium Sulphite	+	+
Stannic Chloride	+	+
Stannous Chloride	+	+
Starch Solution*	+	+
Stearic Acid*	+	+
Sulphuric Acid	+	+
Sulphuric Acid+	+	o
Sulphuric Acid+	+	-
Sulphuric Acid+	o	-
Sulphuric Acid+	o	-
Sulphuric Acid+	-	-
Sulphurous Acid Tallow#	+	+
Tannic Acid*	+	o
Tartaric Acid Tetrahydrofuran#*	+	+
Titanium Tetrochloride Toluene#*	+	+
Trichloroethylene#*	-	-
Triethylene Glycol*	-	-
Trisodium Phosphate	+	+
Turpentine# Urea	-+	-+
Urine	+	+
Vanilla Extract*	+	+
Vinegar	+	+
Water	+	+
Wetting Agents*	+	+
Whiskey*	+	+
Wines*	+	+
Xylene#	-	-
Yeast	+	+
Zinc Bromide	+	+
Zinc Carbonate	+	+
Zinc Chloride	+	+
Zinc Oxide	+	+