



VISTA CLAD APEX TECHNICAL DATA SHEET

VERSION E1.0 | 22/02/2023



Before installing, please ensure you have downloaded the latest version of this TDS by scanning this code.

www.eva-last.com

A PRODUCT BY **EVA-LAST**[®]
INSPIRED BY NATURE, DESIGNED FOR LIFE.

Contents

Document guide	3
Material composition	5
Material compliance	5
Physical properties	6
Mechanical properties	7
Thermal properties	9
Fire reaction properties	9
Weathering	10
System components	11
System properties	17
Disclaimer and copyright	19
Appendix A - Profiles details	20
Appendix B - System component	25
Appendix C - Material compatibility	35

VistaClad Apex

VistaClad is available in beautiful Apex PVC composite technology. Backed by a 30-year warranty, Apex capped composite is an ideal cladding material. The dual colour finish of Apex provides the most natural look available in composite, which embodies the essence of timber in a range of nuanced shades to complement your overall project. Install this ultra-lightweight, low-maintenance cladding vertically or horizontally to suit your style.

Product name:	VistaClad
Product use:	Primarily used in cladding, façades, screens, and similar applications
Material:	Apex
Material description:	Co-extruded profiles with acrylic cap around a foamed mineral-polymer composite core

Document guide

Eva-Last strives to evaluate their products in depth and present the technical and safety information available in a manner that assists with the application thereof. If additional data or information is required, please do not hesitate to contact us at rad@eva-last.com.

In an attempt to simplify the information, similar data is loosely grouped into the categories summarised below. This document is ordered according to these categories and the applicable page number for the start of each section captured in the Table of Contents page above.

- Material composition
- Physical properties
- Mechanical properties
- Thermal properties
- Fire reaction properties
- Weathering properties
- Surface properties

The material compositions section captures a summary of the product make-up from the Material Safety Data Sheet (MSDS). A link to the MSDS is provided for additional detail. Summaries of chemical compliance data available are also collected in this section.

The physical properties section provides a summary of available profiles and general material properties such as density, water absorption, etc. Additional profile information can be obtained from drawings in the appropriate **Appendix A**. Where possible, material properties that can be assigned to more specific categories are moved to the relevant section.

The mechanical properties section captures data related to the products reaction to various load conditions. The section is broadly assembled into the below categories. Additional profile and sectional information are captured by the drawings in the appropriate appendix.

- Material specific mechanical properties
- Profile specific mechanical properties
- Sectional properties

Product properties such as the expansion coefficient, thermal resistance, etc. are captured, where applicable, in the thermal properties section.

Information regarding the products reaction to fire is captured in the fire reaction properties section.

Test data relating to the acoustic performance of the product is summarised in the acoustic properties section.

Information on the products resistance to mold, termites, etc. is collected in the biodegradation properties section.

The surface properties section summarises information regarding the finish or texture of the product. Test data on aspects such as slip resistance (where applicable) is captured in this section.

Where the products form part of a system and, as a result, utilise other components, an additional section to capture useful data regarding these components has been added to this document.

Where information is not yet available, the section has been omitted. In the cases where information can be substituted or supplemented with alternative data (based on similar compositions, etc.) an attempt to do so is made. Where this is the case, it is highlighted. Please make use of the data accordingly. For any additional information regarding this, please feel free to contact rad@eva-last.com.

Ensure the product and application thereof is suitable, rational, and compliant with any applicable regulations or standards. Wherever necessary, consult a suitably qualified professional. For information about the installation and use of the product, please see the applicable Installation Guide (IG). For additional material safety and handling information, please refer to the applicable MSDS. For any further information, please contact rad@eva-last.com.

Material composition

The following table is a simplified material composition for the Apex material technology. For more information regarding the composition, safety, and handling of the material, please see the Apex MSDS. Please also refer to the safety section and the Safe Working Procedure (SWP) in the IG for additional information related to the safe use of these products. To confirm which substances are compatible, or incompatible, with the product, please refer to Appendix B.

Component	Substance	Mass (%)
Core	Poly chloroethylene (PVC)	51%
	Calcium carbonate	30%
Cap	Acrylonitrile styrene acrylate copolymer (ASA)	10%
Additional additives	Other	9%

Material compliance

Apex has been assessed to determine whether it contains Substances of Very High Concern (SVHC) that may be classified as carcinogenic, mutagenic, or toxic to reproduction of humans or animals, or have a persistent, cumulative, or negative impact on the environment in accordance with European REACH (Registration, evaluation, and authorization of chemicals) regulations.

Compliance report	Result	Issue date	Compliance body	Information
SVHC	Pass	2019-06	EU REACH	Of the 197 substances evaluated, non-have been detected. SVHC concentration require detection levels of less than 0.05% of the whole product. See this link for the full list of substances.

Physical properties

General material properties

Typical properties of the Apex material technology are captured below as an indication of the expected behaviour of the Apex material.

Properties	Results	Test method	Information
Density	650 to 750 kg/m ²	ASTM D2395	
Moisture content	0.35%	ASTM D4442-15	Tested according to International Code Council, Evaluation Service (ICC-ES) AC 174 requirements by an independent third-party laboratory. Results of the issued Code Compliance Research Report (CCRR) are captured here . Results assumed to be applicable to all profiles.
Water absorption (Mass)	1.12%	ASTM D7031-11-5.19	
Water absorption (Dimensional)	0.09%	ASTM D1037-12	

Profile properties

The following table is a summary of the currently available profiles, please see [Appendix A](#) for profile drawings.

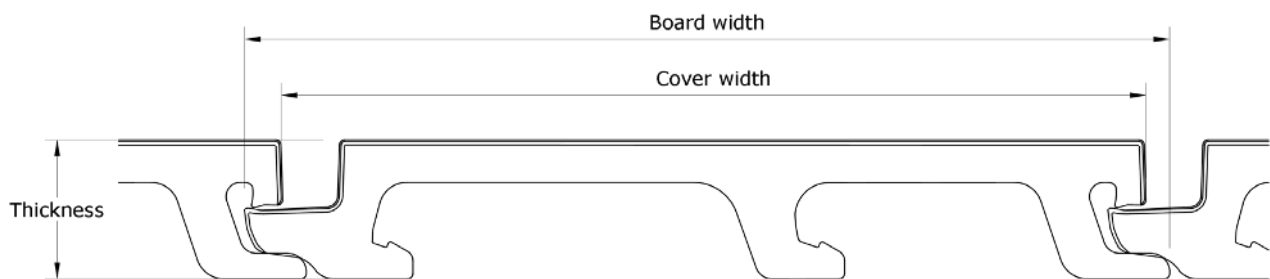

Profile ID	Board width (mm)	Thickness (mm)	Mass (kg/m)	Cover width (mm)	Coverage (m ² /m ²)	Coverage mass (kg/m ²)	VistaClad trim compatibility
STTHM202	163.0	24.5	1.3	152.6	6.6	8.5	Yes
STTHM203	163.0	24.5	1.4	152.6	6.6	9.2	Yes
STTHM204	163.0	24.5	1.5	152.6	6.6	9.8	Yes
STTHM205	86.0	34.5	0.9	76.3	13.1	11.8	No

Mechanical properties

Material specific mechanical properties

All information within this table is currently based on internal laboratory results of Apex.

Properties	Result	Test method	Information
Abrasion resistance	116 mg (1 000 cycles)	ASTM D4060	To estimate the wear resistance of the Apex cap, the product was subjected to abrasive wheels carrying 1kg loads at 60 rotations a minute for 1 000 cycles.
Hardness Shore D	82	Shore D	A standardised test to determine the depth of penetration of a specific indenter. Results greater than 60 fall under the category "extra hard".
Modulus of Elasticity (MOE)	1 756 to 2 068 MPa	GB/T 17657	As the MOE can be considered as a material property, the information has been provided as a summary of the flexural performance tests below. The MOE can be dependent on the profile and/or span.

Profile flexural performance testing

Flexural properties of polymer composites can be influenced by the profile geometry and/or span. Typical properties of the Apex material technology are captured below based on internal test results as an indication of the expected behaviour of the products.

Profile	Span (mm)	Ultimate Load (kN)	Flexural strength MOR (MPa)	Flexural stiffness MOE (MPa)	Test method	Information
STTHM202, 24.5 x 160 mm	400	2.7	30.3	1 566	GB/T 17657	Internal reports summarising flexural performance of individual profiles at different spans. Further testing is underway.
STTHM203, 24.5 x 160 mm		3.0	30.8	1 594		
STTHM204, 24.5 x 160 mm		2.9	31.5	1 576		
STTHM205, 34.5 x 160 mm		3.8	33.2	1 609		
STTHM202, 24.5 x 160 mm	550	1.7	26.9	1 769		
STTHM203, 24.5 x 160 mm		1.7	26.8	2 068		
STTHM204, 24.5 x 160 mm		2.0	30.9	1 980		
STTHM205, 34.5 x 160 mm		3.0	36.9	1 756		

Impact of weathering (material factor estimate)

Material properties can vary as a result of long-term weathering. To estimate this impact on the material's flexural properties, the product is subjected to various weathering effects and the performance with and without weathering is compared. The overall end-use adjustment factor is selected based on the weathering effect that has the most impact on the material.

Properties	Flexural strength	Flexural stiffness	Adjustment factor	Test method	Information
High temperature effect	18 %	24 %	0.76	ASTM D7032 - 17, ASTM D2565, and ASTM D790.	To confirm compliance with ICC-ES AC 174, Apex decking profiles were evaluated by an independent third-party laboratory. The profiles were tested at a span of 12 in or 304.8 mm. The results of the issued CCRR can be found here .
Low temperature effect	-26 %	-14%	1.00		
Moisture effect	-3 %	4 %	0.96		
UV resistance	-6 %	1 %	1.00		
Freeze-thaw resistance	1%	13 %	0.97		
Overall end-use adjustment factor			0.76		

Flexural tests were conducted to failure at the specified span per ASTM D7032 per the bellow table. The average changes in properties between the control specimen and tested specimens were calculated as a percentage.

Property test	Conditions	Duration
Temperature effect	-29 to 52 °C (±2°C)	N/a
Moisture effect	At moisture conditions expected in service.	24 Hour
Ultraviolet resistance	Per ASTM G151, Specimens are exposed to repetitive cycles of light and moisture.	2 000 Hours of exposure in accordance with cycles in accordance with ASTM G151
Freeze-thaw resistance	Profile specimens are Submerged under weights for 24 hours, then frozen at -29°C for 24 hour, then thawed at ambient temperatures for 24 hours.	3 cycles at 72 Hours per cycle.

Sectional properties

The following table provides a sectional property summary of the currently available VistaClad Apex profiles. Please see **Appendix A** for profile drawings and further information.

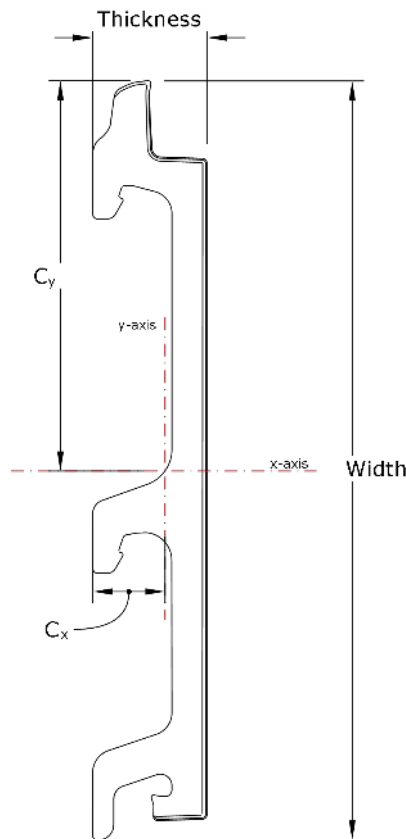

Profile ID	Width (mm)	Thickness (mm)	Area (mm ²)	I _x (mm ⁴)	I _y (mm ⁴)	C _x (mm)	C _y (mm)	S _x (mm ³)	S _y (mm ³)
STTHM202	163	24.5	1814	4 242 587	94 586	15.5	84.1	50 459	6 098
STTHM203	163	24.5	1925	4 297 595	93 467	15.1	82.8	51 895	6 190
STTHM204	163	24.5	2 021	4 401 140	91 584	14.8	84.4	52 172	6 209
STTHM205	86	34.5	1256	825 304	151 733	19.7	47.5	17 359	7 683

Thermal properties

Typical properties of the Apex material technology are captured below as an indication of the expected behaviour of the Apex products.

Properties	Results	Test method	Information
Coefficient of thermal expansion (CTE)	46.2 x 10 ⁻⁶ mm/mm.°C	ASTM D696-16	An expansion coefficient was determined for temperatures ranging between -30°C and 30°C. The results of the issued CCRR can be found here .

Fire reaction properties

Typical fire reaction properties of Apex and Apex fire-resistant (FR) material technologies are captured below.

Apex fire reaction properties

Standard	Properties	Result	Requirement	Test Method	Information
EN 13501	Fire growth rate (FIGRA) threshold 0.4MJ	3 098 W/s	Less than 750 W/s	EN 13823	The Apex (normal) material was tested by an independent third-party laboratory in a typical cladding application. The STTHM202 and STTHM203 cladding profiles were both tested. The report can be found here .
	Total heat release (THR) at 600 s	67 MJ			
	Smoke growth rate (SMOGRA)	440 m ² /s ²	Less than 180 m ² /s ²		
	Total smoke production (TSP) at 600 s	1 322 m ²	Less than 200 m ²		
	Droplets	Yes	No		
ICC-ES AC 174	Flame spread index (FSI)	35	Less than 200	ASTM E84	Apex (normal) deck profiles were tested as part of ICC-ES AC 174. The orientation of this test is more suited for cladding applications. The results of the issued CCRR can be found here .
	Smoke development index (SDI)	1 300	Less than 450		
Wildland Urban interface (WUI)	Heat release rate	~148 kW/m ²	25 kW/m ²	CA SFM 12-7A-4A (Decking application)	Cladding specific test results according to this standard are not currently available. These results are for Apex (normal) deck profiles. The report can be found here .
	Absence of flaming or glowing combustion	Pass	No flaming for 40 minutes		
	Absence of falling particles	Pass	No observed particles		

Apex FR fire reaction properties

Standard	Properties	Result	Requirement	Test Method	Information
EN 13501	Fire growth rate (FIGRA) threshold 0.4MJ	68.7 W/s	Less than 750 W/s	EN 13823	The Apex FR material was tested by an independent third-party laboratory with a cladding profile in a typical cladding application. The report can be found here .
	Total heat release (THR) at 600 s	1.2 MJ			
	Smoke growth rate (SMOGRA)	37.6 m ² /s ²	Less than 180 m ² /s ²		
	Total smoke production (TSP) at 600 s	301.5 m ²	Less than 200 m ²		
	Droplets	Yes	No		

Weathering

Most materials are susceptible to weathering. The environment, and factors such as Ultraviolet (UV) light exposure, oxidation and contact with organisms (termites, mold, etc.), to which the materials are exposed will influence the rate of deterioration. The impact of weathering on the flexural performance (material factor estimate) of the products is captured in the Mechanical properties section above.

Colour fade

Weathering over time can result in a colour change of the material. ΔE is a common form of measurement for colour fade. The ΔE denotes the colour difference between an original sample and a tested sample after different levels of exposure to UV light (and potentially other weathering effects). ΔE is measured on a scale of 1 to 100 and attempts to provide a simple metric of how the human eye perceives colour change. Both 'light' and 'dark' colours are tested to provide an indication of the range of performance of the product.

Standard	Colour Reference	ΔE	Grey scale	Test method	Information
ICC-ES AC 174	Arctic birch (CG005)	1.3	4	ASTM G155-13 4 000 Hours	Change perceptible through close observation. As part of ICC-ES AC 174 requirements. The results of the issued CCRR can be found here .
	Brazilian teak (CB010)	1.1	Not determined	ASTM G154-7 3 000 Hours	Change perceptible through close observation.
	Himalayan Cedar (CL014)	1.72	Not determined		Change perceptible through close observation.
	Hawaiian Walnut (CB013)	2.26	Not determined		Change perceptible at a glance.

Biodegradation

Materials exposed to organisms such as termites or mould can degrade as a result.

Decay resistance

Mold resistance tests are not required for products without significant cellulose materials within the composition.

Termite resistance

Termite resistance tests are not required for products without significant cellulose materials within the composition.

System components

The following section provides a brief overview of the system components and ancillary items with which the Apex cladding profiles interact. Please see Appendix B for drawings.

Cladding clip strips

Material specific properties

Typical mechanical properties for ISQ 230 (AMSA) from online sources.

Properties	Value	Notes
Typical yield strength	230 MPa	Typical for ISQ 230 (SANS 4998 Gr220, ASTM A653 Gr230 CS type A, EN 10346 DX 51D, JIS G3302 SGCC)
Ultimate tensile strength	270 to 500 MPa	
Modulus of Elasticity	200 GPa	
Bulk Modulus	160 GPa	
Poisson Ratio	0.29	
Shear modulus	80 (GPa)	

Profile specific strength properties

The individual 'supports' of the clip strip that hold the boards in once installed were tested to provide an indication of a yielding point under a negative load. These springs were loaded (F_{load} in schematics below) individually with a custom-made jig that would result in the maximum moment being generated (attempting to replicate a worst-case scenario). The strips were supported with fasteners (F_{screw} in schematics below) into a secure substructure using the holes provided in the strips: two through the front face of the flat strip either side of the point of application of the tensile load and four through the bottom flanges of the top hat.

The yield load captured below is an indication of the load at which a single clip deforms to an extent that would allow the respective part of the board profile to escape the clip. This load provides an indication of the maximum load that a single clip strip interaction can support. It is suggested that this would be

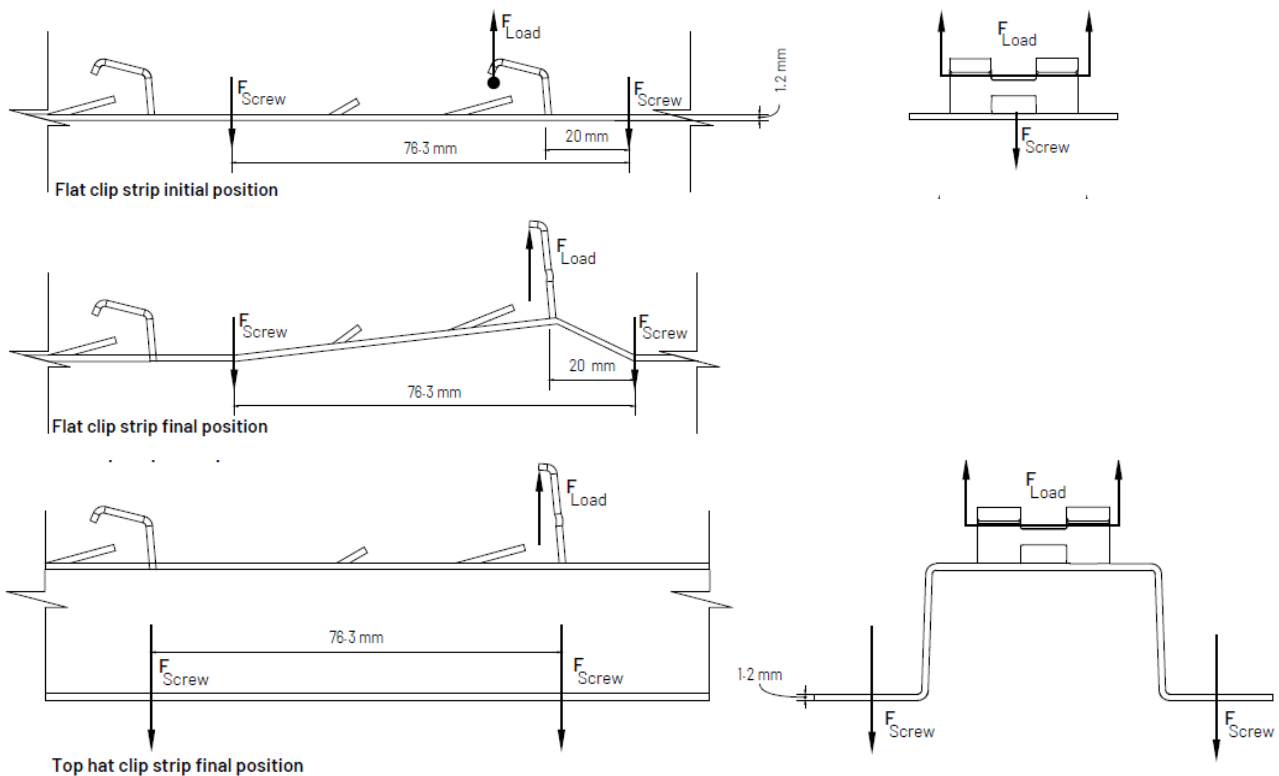



conservative when considering the interaction of multiple clip strips and boards together. In this scenario, it is expected that a larger load would be required to create enough deformation that would facilitate the release of a board or part thereof. These assessments assumes adequate interaction between the board and clip strip, and appropriate fixing of the clip strip to the substructure/substrate. Note that the tests conducted on the flat strips resulted in localized separation (see final flat clip strip schematic above) of the clip strip from the support structure during loading (a potential explanation of the differences in results below). This highlights the need for appropriate fixing frequency between this part and the substructure/substrate (in addition to fastener withdrawal limitations).

Item	Min. yield load (N)	Average yield load (N)	Test method	Information
Flat strip	431	595	N/A	Simple tensile tests were conducted by an independent third-party laboratory. Five samples of the flat strip and five samples of top hat strip were tested. The performance of the top hat strip is assumed to be indicative of that of the channel strip.
Channel	374	429		
Top hat	374	429		

Weathering (Corrosion information)

Part	Specification	Thickness	Notes
Steel substrate	ISO 230	1.2 mm	All clip strip types are 1.2 mm thick.
Galvanisation	Z275	19 µm	Supplier information.
Powder coating	Ferro VEDOC VP Polyester (matt black)	60 to 80 µm	Supplier information.

Profile properties

Item	Description	Material	Width (mm)	Gauge (mm)	Depth (mm)	Ventilation gap (mm)	Length (mm)	Mass (kg/part)
Flat strip		Galvanised steel ISO 230 (Z275) Powder coated	40	1.2	12	1.2	1831	0.7
Channel			1831	45	1.2	34	>23.5	1.5
			2745	86	1.2	36	25.4	2.2
Top hat		1831	86	1.2	36	25.4	2.2	
		2745					3.2	

Sectional properties

Section properties provided are based on profile shapes and do not include gaps and holes within the final part.

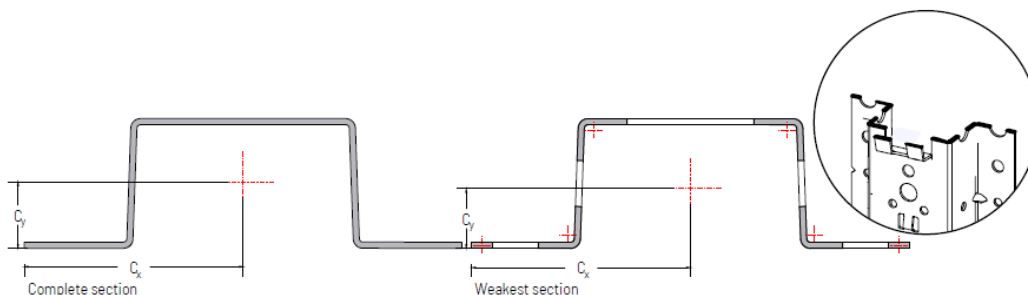

Item	Width (mm)	Thickness (mm)	Area (mm ²)	I _x (mm ⁴)	I _y (mm ⁴)	C _x (mm)	C _y (mm)	S _x (mm ³)	S _y (mm ³)
Flat strip	40	1.2	48	6	6 400	20.0	0.6	10	320
Flat strip adjustment			18	2.2	4 889	20.0	0.6	3.7	244
Channel	45	1.2	105	5 820	33 006	22.7	16.9	345	1 455
Channel adjustment			54	3 775	21 334	22.7	16.0	235	950
Top hat	86	1.2	156	17 166	87 585	42.7	12.8	1 338	2 050
Top hat adjustment			83	9 446	50 452	42.7	11.8	802	1 180

Fasteners

The following table provides a quick reference list of typical fasteners that may be used for various substrates. This information has been collected from several manufacturers for convenience and is presented herein to provide indicative performance. Please refer to applicable manufacturers for further information and/or confirmation of the suitability of the application. Appropriate fasteners must be utilised. Particular attention should be paid to substructure/substrate and environmental conditions (particularly with respect to corrosion) of the site. All applications should adhere to applicable standards. All timber and metal profiles should be treated and/or coated appropriately. Regular proactive maintenance is advised where possible.

Application	Fastener type	Material	Size (mm)	Tensile (kN)	Ultimate Shear (kN)	Withdrawal resistance (kN)	Edge distance	Minimum spacing	Minimum substructure material specification
Timber	Wafer head	C1022 case hardened	M5.5 x 45	13.9	8.4	3.9	Ø x 5 = 28 mm	Ø x 5 = 28 mm	Pine - F7 rated at 36 mm embedment
	Tek screw		M5.5 x 50						
Steel	Wafer head	C1022 case hardened	M5.5 x 22	15.3	8.8	2.2	Ø x 2 = 12 mm	Ø x 2 = 12 mm	Steel - 1.2 mm thick
			4.0			Steel - 1.5 mm thick			
			5.4			Steel - 1.9 mm thick			
	Tek screw		M5.5 x 25			7.4			Steel - 2.4 mm thick
Masonry	Hilti HPS-16 PE sleeved anchor*	Carbon steel, galvanised	M 6.0 x 40	0.25	0.35	Not available	30 mm	30 mm	Devoid of cracks and similar. Typical embedment depth of 30 to 40 mm. Confirm adequate strength. Refer to Hilti TDS.
	Hilti HUS3-P Concrete screw*	Carbon steel, galvanised	M5.0 x 40	2.8	3.9	Not available	35 mm	35 mm	Devoid of cracks and similar. Typical embedment depth of 40 mm. Confirm adequate strength. Refer to Hilti TDS.

Typical Fastener specifications and coating

Screw corrosion classification





The following table provides a summary of materials and coatings typical fasteners used by Eva-last.

Fastener category	Material Details			
	Size	Material	Coating Type	Coating Thickness
Carbon clip screws	M4.2			
Carbon deck screws	M5.0	C1022	Magni 599 (full coat)	20 µm
Carbon Frame screws	M6.0			
Carbon trim screws	M5.5	10B21		20 µm
Tek screw	M5.5	C1022	Class 3	25 µm
	M5.5		Class 4	50 µm
	M5.5		Zinc Plated	8 µm
Stainless clip screw	M4.2	SS316	Magni 599 (full coat)	20 µm
Stainless deck screw	M5.0		Enamel head coating	N/a
Stainless trim screw	M5.5			

Nylon adaptors

Profile properties





The following list of adaptors is designed for use with the cladding clip strip and trim listed below. See the IG for further details.

Item	Description	Material	Associated trim	Width (mm)	Height (mm)	Length (mm)	Mass (g)
Top and bottom adaptor		Glass fibre reinforced nylon composite		50	70	23	9
Side adaptor		Glass fibre reinforced nylon composite	Universal trim	50	95	23	15
Internal corner adaptor		Glass fibre reinforced nylon composite	Internal corner trim profile	54	54	40	10
External corner adaptor		Glass fibre reinforced nylon composite	External corner trim profile	71	71	40	8

Aluminum trim

Profile properties

The following list of trim profiles is designed to be compatible with the respective adaptors listed above. See the IG for further details.

Item	Description	Material	Associated adaptor	Width (mm)	Height (mm)	Mass (kg/m)
Universal trim profile		Aluminium 6063-T5, powder coated	Top and bottom adaptor and Side adaptor	25	50	0.37
T trim profile		Aluminium 6063-T5, powder coated	Side adaptor	25	40	0.26
U trim profile		Aluminium 6063-T5, powder coated	Side adaptor and Top and bottom adaptor	13	21	0.17
Internal corner trim profile		Aluminium 6063-T5, powder coated	Internal corner adaptor	51	59	0.50
External corner trim profile		Aluminium 6063-T5, powder coated	External corner adaptor	51	51	0.51

Weathering (Corrosion information)

Part	Specification	Thickness	Notes
Aluminium substrate	6063-T5	0.9 mm	Thinnest part of various trim parts.
Powder coating	Polyester (multiple colour options)	60 to 80 µm	Supplier information.

Board sealant volume requirements

A summary of suggested sealant volumes per application is provided below for convenience. The volume of sealant per board face is in reference to a suggested bead to be placed on the underside of the trim before inserting the trim into the adaptors. The volume of sealant at the groove refers to the cavity created beneath the trim at the tongue and groove joint between two consecutive boards and/or at the groove(s) within the board profile. Refer to the IG for further information.

Profile	Quantity of grooves	Volume of sealant to seal the board face (ml)	Volume of sealant to fill grooves. (ml)	Total Volume of sealant per board (ml)	Total volume of sealant per meter of trim (ml/m)	Information
STTHM202	1		1.2	4.0	26.2	The volume required between trim and boards are based off a 5 mm diameter bead assumption. See Appendix A for groove sizes.
STTHM203	2	2.8	2.4	5.2	34.0	
STTHM204	3		3.6	6.4	42.0	
STTHM205	1	1.3	7	3.5	46.4	All volumes are estimations and do not include shrinkage.

Potential liquid sealants to consider (application dependent):

Soudal Silirub Colour

Loctite PL Heavy Duty Sealant

Loctite 100% Silicone

Loctite PL Roof and Flashing Sealant

Alcolin Alco Flex Neutral Silicone

System properties

The VistaClad system consists of the board profiles, clip strips and trim system installed on some form of substructure. The results captured below are based off of internal tests and/or finite element analyses (FEA). The internal tests are conducted using a pressurised 3.0 m by 3.6 m test chamber. The chamber allows for varying positive pressures to be applied and for water to be sprayed at differing rates. These results are believed to be indicative and are presented to provide a gauge of performance of an installed system until independent test data is available.

System strength

Test 1: Evaluation of system strength in STTHM202 in a flat wall test.

An installed system of the STTHM202 profile with supports (substructure and clip strips) at 600 mm spans was tested under positive pressures in excess of 3 kPa, the results of which showed no significant yielding of any of the system elements. Internal FEAs supported this result. The internal test rig is not yet capable of generating meaningful negative test pressures, as a result internal FEAs were used to supplement this scenario. Simulations at negative pressures of 1 kPa indicated no significant yielding of any of the system elements. Typical simulation assumptions were made between interactions of components, fixtures to substrate, material homogeneity, and load application.

Test 2: Evaluation of system strength in STTHM203 and STTHM204 in a E2-VM1 test.

A test sample was created per E2-VM1 requirements consisting of a majority of STTHM204 and approximately 5% of STTHM203 profiles and were used for E2-VM1 testing rig per the water ingress testing below. Per the previous tests supports (Substructure and clip strips) at 600 mm spans was tested under positive pressure more than 50 Pa, the results of which showed no significant yielding of any of the system elements.

Water ingress

The water ingress assessment of the system attempted to follow the evaluation of E2-VM1 Verification Method employed by the New Zealand Building Regulations and Australian National Construction Code. Additional test detail is provided in NZS 4284 (Testing of building façades).

Test 1: Evaluation of STTHM202 in a flat wall test.

The Wet wall test method (Section 1.4.5) was utilised on a system with the STTHM202 profile installed at 600 mm spans. The requirement to pass this assessment is for no splashing to occur up to a pressure of 50 Pa for certain periods of time. Initial water ingress was recorded at approximately 125 Pa and water ingress that would be considered (internal assessment) a test failure at approximately 150 Pa.

Test 2: Evaluation of STTHM203 and STTHM204 in a E2-VM1 test.

According to the wet wall test method described above, STTHM203 and STTHM204 profiles were installed at 600 mm spans, meeting identical requirements. The internal simulation for testing followed the established E2-VM1 test methods per the diagram below. To pass this assessment, it was necessary to ensure that no splashing occurred up to a pressure of 50 Pa for specified time periods.

Test 3: Evaluation of full system with STTHM203 and STTHM204 in a E2-VM1 test.

The assessment process included conducting individual evaluations of each component within the complete assembly during testing. The lowest performing pressure result within each component of the assembly was recorded. For an overview, please refer to the table below, which summarizes the performance of each specific assembly. Details regarding any additional flashing parts utilized can be found in **Appendix A**. The primary sealant employed was Alcolin Alco Flex Neutral Silicone, along with standard flashing tape. For further information, please consult the Installation Guide (IG) for relevant assembly details.

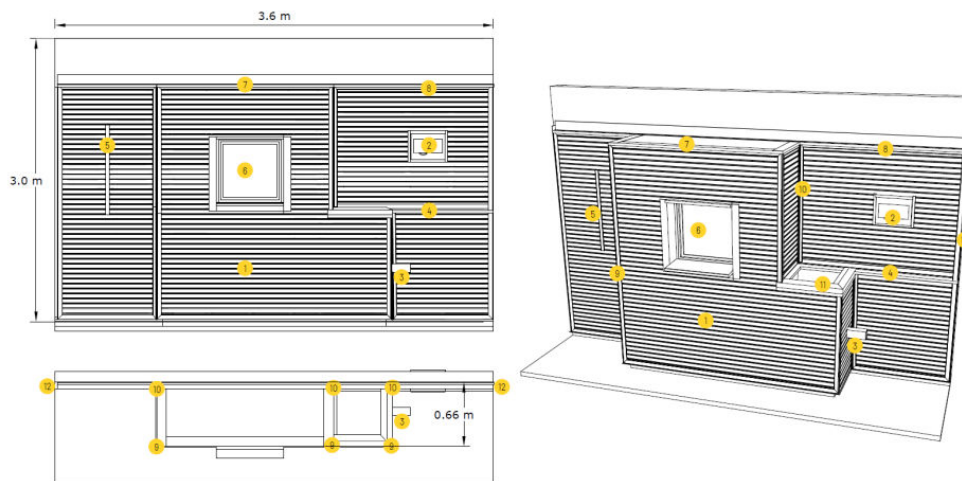

Summary of E2-VM1 Internal test results (Pressure range up to 100 Pa)

Assembly	Static water ingress	Result at 50 Pa	Maximum pressure achieved before leak to wet wall	Observed impact on parts at pressure spike greater than 2 770 Pa
1. Apex STTHM202	Pass - Not part of test	N/a	Same tongue and groove as STTHM203 and 204.	
Apex STTHM203	Pass	Pass	> 100*	
Apex STTHM204	Pass	Pass	> 100*	Single leak found between profile joints
Joint between STTHM203 and 204	Not part of test	N/a	> 100*	
Apex STTHM205	Pass	N/a	Same tongue and groove as STTHM202,203 and 204.	
2 Electric box	Pass	Pass	> 100*	Leaked through fastener hole inside the electric box
3 Gutter Penetration	Pass	Pass	> 100*	
4 Horizontal joint (Second story joint)	Pass	Pass	> 100*	
5 Vertical joint (Butt joint)	Pass	Pass	80	
6 Window	Pass	Pass	100	Leak started at one corner. Causing problems throughout remaining testing.
7 Flat roof	Pass	Pass	> 100*	Composite profile above window spanned 1 000mm. Collapsed inward opening joint between board and trim
8 Perpendicular roof join	Pass	Pass	> 100*	
9 External corner	Pass	Pass	> 100*	Isolated leak that did not hit wet wall. Pressure caused silicon seals to break.
10 Internal corner	Pass	Pass	> 100*	Isolated leak that did not hit wet wall. Pressure caused silicon seals to break.
11 Parapet	Pass	Pass	86	
12 Edges	Pass	Pass	> 100*	

*Did not leak to wet wall

Disclaimer and copyright

Document disclaimer

The provided information is offered in good faith as accurate but without guarantee. Eva-Last makes no warranties or representations of any kind (express or implied) about the accuracy, adequacy, currency, or completeness of the information, or that it is necessarily suitable for the intended use.

Compliance with this document does not guarantee immunity from breach of any statutory requirements, building codes or relevant standards. The final responsibility for the correct design and specification rests with the designer and, for its satisfactory execution, with the contractor. Appropriate warnings and safe handling procedures should be provided to handlers and users.

While most data have been compiled from research, case histories, experience and testing, small changes in the environment can produce marked differences in performance. The decision to use a material, and in what manner, is made at your own risk. The use of a material and method may therefore need to be modified to its intended end use and environment.

Eva-Last, its directors, officers or employees shall not be responsible for any direct, indirect, or special loss or damage arising from, or as a consequence of, use of, or reliance upon, any information contained in this document or other documents referenced herein. Eva-Last expressly disclaims any liability which is based on or arises out of the information or any errors, omissions or misstatements herein.

Drawing disclaimer

All dimensions and specifications are offered in good faith as accurate but without guarantee. The information captured herein may not contain complete details. Eva-Last makes no warranties or representations of any kind (express or implied) about the accuracy, adequacy, currency, or completeness of the information, or that it is necessarily suitable for the intended use.

Compliance with this document does not guarantee immunity from breach of any statutory requirements, building codes or relevant standards. The final responsibility for the correct design and specification rests with the designer and, for its satisfactory execution, with the contractor.

Utilisation disclaimer

Legislation may differ between jurisdictions. Before installing any Eva-Last product, ensure that the application is rational and complies with the local regulations and building codes. Wherever necessary, consult a suitably qualified professional. Be sure to comply with material manufacturer specifications. Where manufacturers and building codes differ, revert to the building code requirements. Check that your choice of product is suitable for its intended application. For further product specification and information visit www.eva-last.com.

Copyright

If reprinted or reproduced or utilised in any form Eva-Last should be acknowledged as the source of the information.

Eva-Last periodically updates the information contained in this document as well as that of the Eva Last documents that have been referenced herein. Before using this document, please refer to the Eva-Last website (www.eva-last.com) for the most up-to-date documents.

Contact information

Eva-Last

Room 1203, 12/F Tower 333 Canton Road, Tsimshatsui, Hong Kong, China

Emergency Contact: +86 021 53397986

Product information: +27 10 593 9220

Email: info@eva-last.com

Website: www.eva-last.com

Appendix A

Profiles details

Profile properties	
Product code	STTHM202
Sectional area (mm ²)	1 814
Approximate mass (kg/m)	1.4



Sectional properties	
I _x (mm ⁴)	4 242 587
I _y (mm ⁴)	94 586
C _x (mm)	15.5
C _y (mm)	84.1
S _x (mm ³)	50 460
S _y (mm ³)	6 099

Drawing title
Profile properties - STTHM202

File name
2022-09-25 - VistaClad profiles

File details

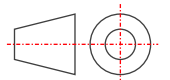

Drawing number	01
Date	March 3, 2023
Page	1 of 8
Scale	NTS

Unless otherwise specified all dimensions are in millimeters.

Issued for information. See supporting documentation for disclaimers and details.

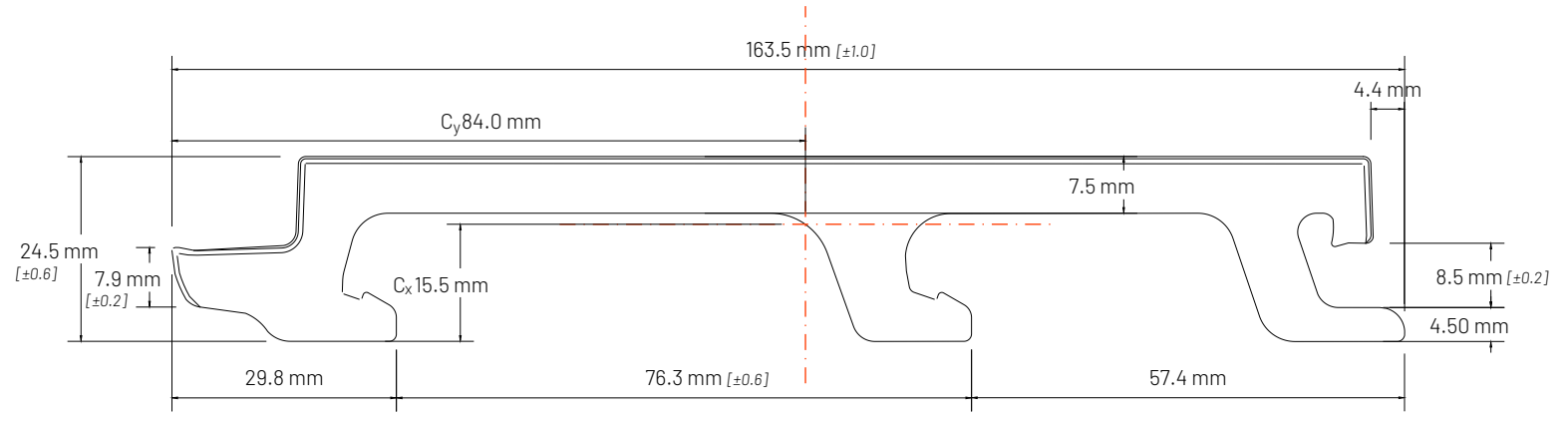

STTHM202 - Profile
Scale 1:1

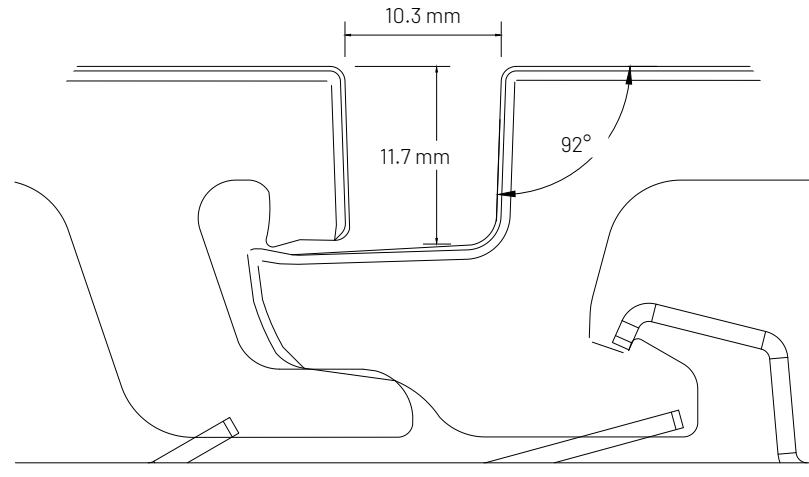

STTHM202 - Tongue and groove interaction
Scale 2:1

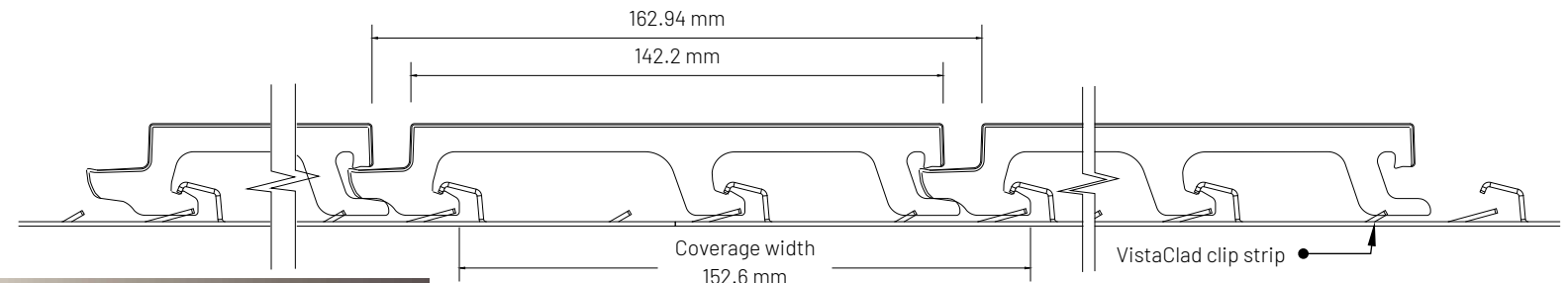

STTHM202 - Board and clip strip interaction
Scale 1:2

Profile properties

Product code	STTHM203
Sectional area (mm ²)	1925.2
Approximate mass (kg/m)	1.4

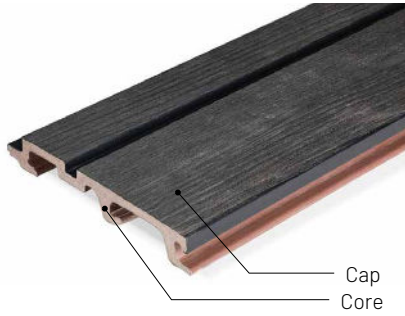

Sectional properties

I_x (mm ⁴)	4 297 594
I_y (mm ⁴)	93 468
C_x (mm)	15.1
C_y (mm)	82.8
S_x (mm ³)	51 895
S_y (mm ³)	6 190

Drawing title

Profile properties - STTHM203

File name

2022-09-25 - VistaClad profiles

File details

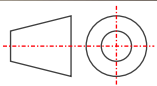

Drawing number	01
Date	March 3, 2023
Page	2 of 8
Scale	NTS

Unless otherwise specified all dimensions are in millimeters.

Issued for information. See supporting documentation for disclaimers and details.

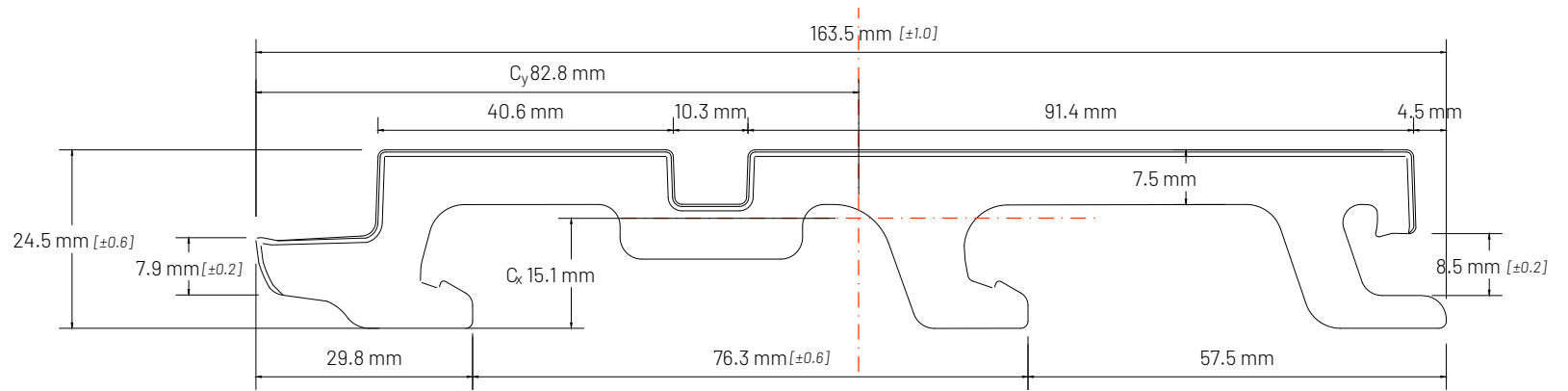

STTHM203- Profile

Scale 1:1

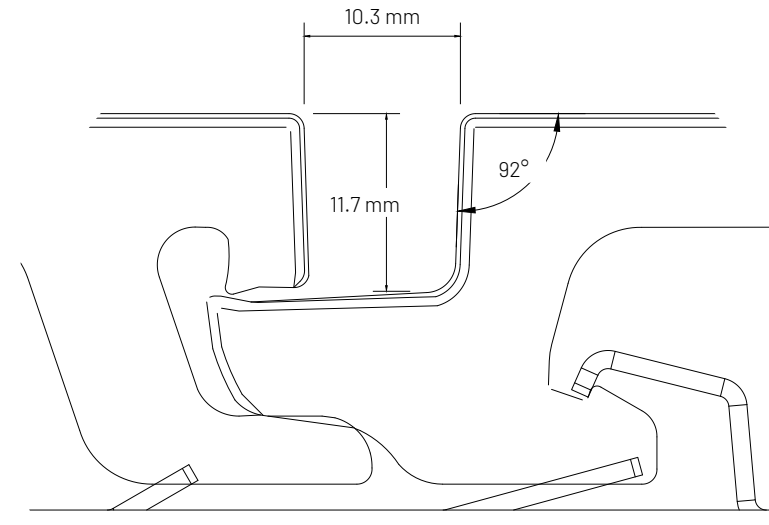

STTHM203 - Tongue and groove interaction

Scale 2:1

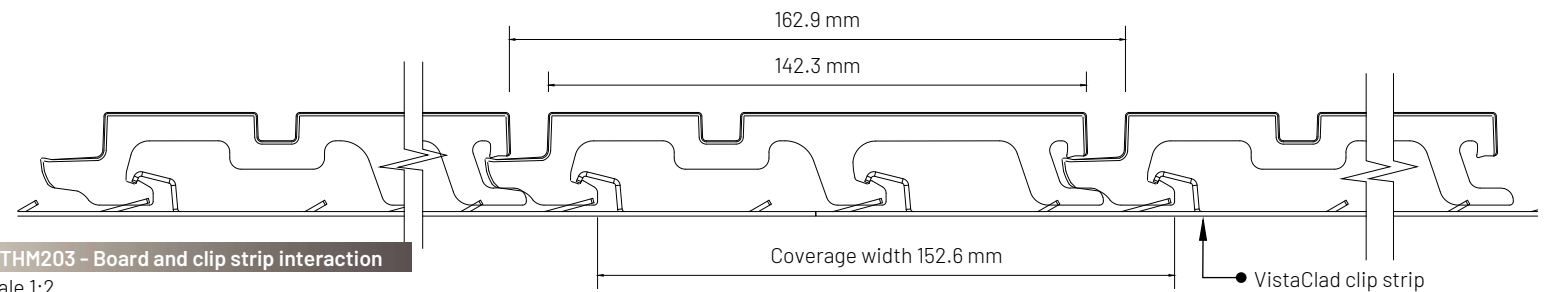

STTHM203 - Board and clip strip interaction

Scale 1:2

Profile properties

Product code	STTHM204
Sectional area (mm ²)	2021
Approximate mass (kg/m)	1.5

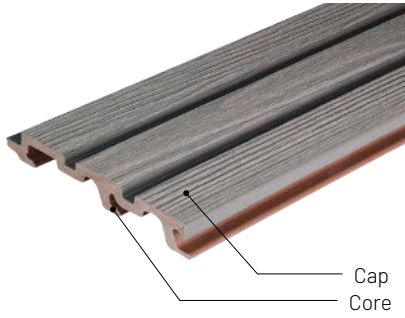

Sectional properties

I _x (mm ⁴)	4 401 139
I _y (mm ⁴)	91 584
C _x (mm)	14.8
C _y (mm)	84.1
S _x (mm ³)	52 172
S _y (mm ³)	6 209

Drawing title

Profile properties - STTHM204

File name

2022-09-25 - VistaClad profiles

File details

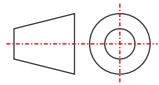

Drawing number	01
Date	March 3, 2023
Page	3 of 8
Scale	NTS

Unless otherwise specified all dimensions are in millimeters.

Issued for information. See supporting documentation for disclaimers and details.

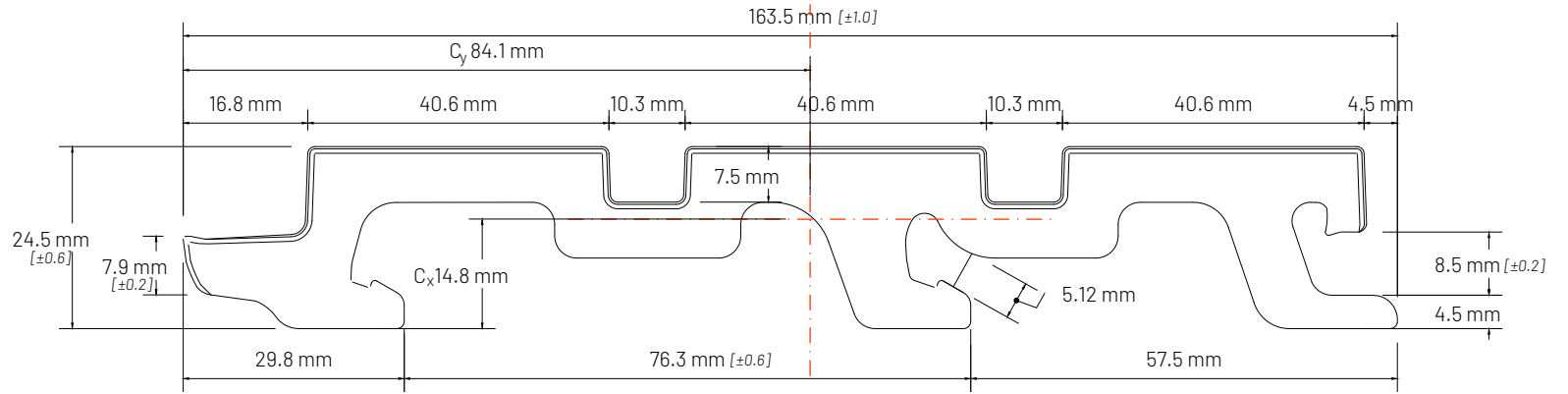

STTHM204 - Profile

Scale 1:1

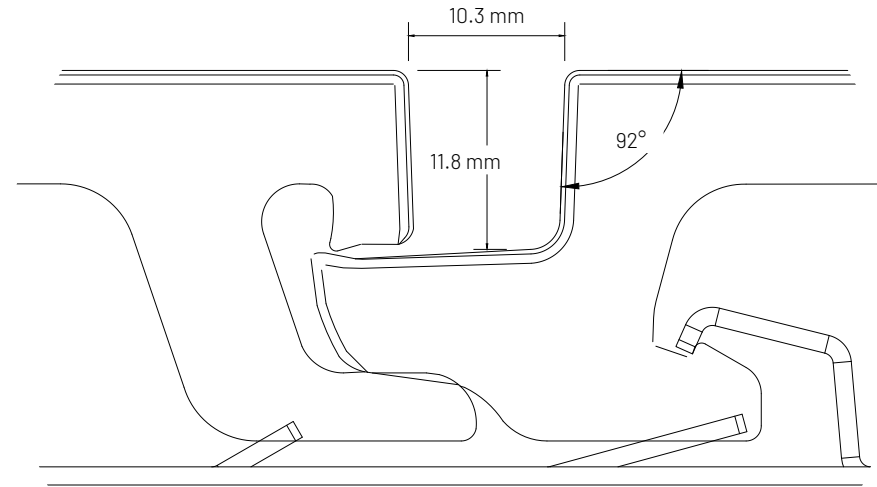

STTHM204 - Tongue and groove interaction

Scale 2:1

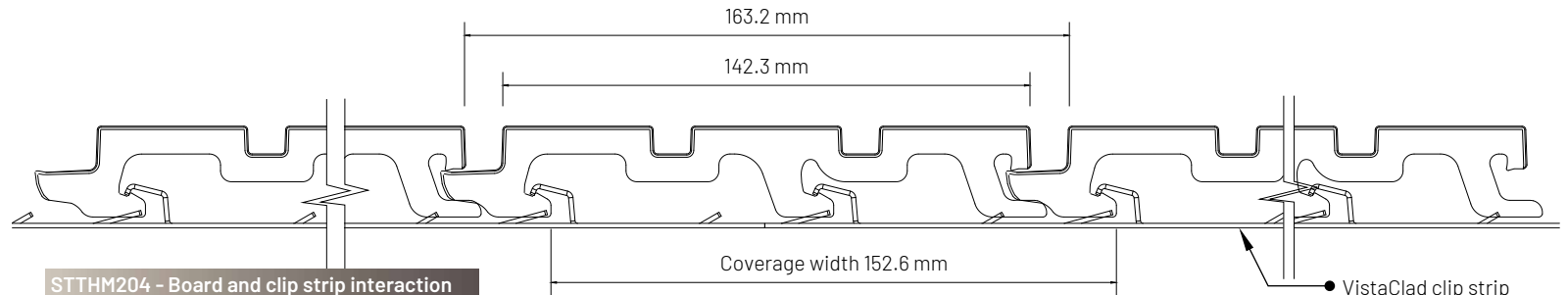

STTHM204 - Board and clip strip interaction

Scale 1:2

Profile properties

Product code	STTHM205
Sectional area (mm ²)	1256
Approximate mass (kg/m)	0.9

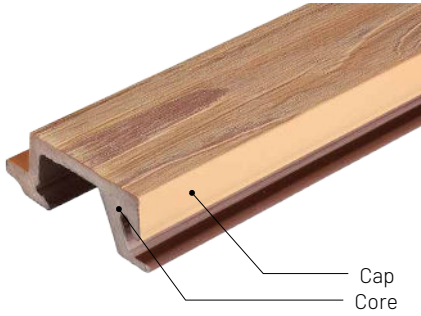

Sectional properties

I _x (mm ⁴)	825 304
I _y (mm ⁴)	151 733
C _x (mm)	19.7
C _y (mm)	47.5
S _x (mm ³)	17 360
S _y (mm ³)	7 684

Drawing title

Profile properties - STTHM205

File name

2022-09-25 - VistaClad profiles

File details

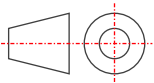

Drawing number 01

Date March 3, 2023

Page 4 of 8

Scale NTS

Unless otherwise specified all dimensions are in millimeters.

Issued for information. See supporting documentation for disclaimers and details.

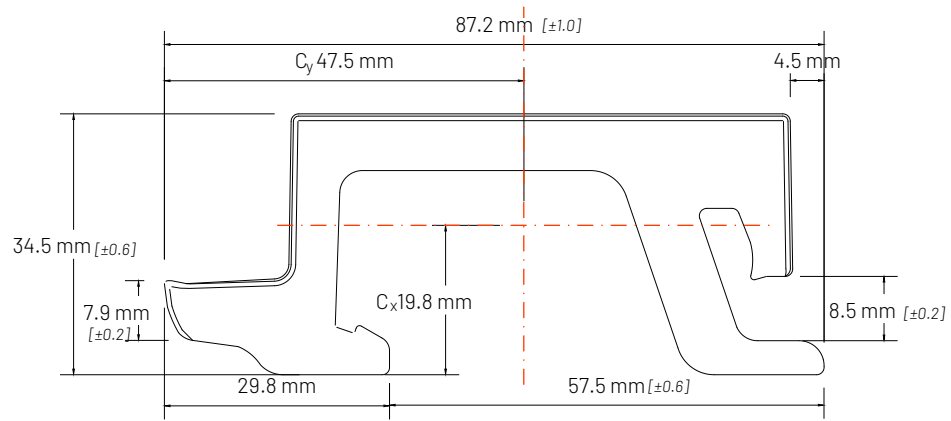

STTHM205 - Profile

Scale 1:1

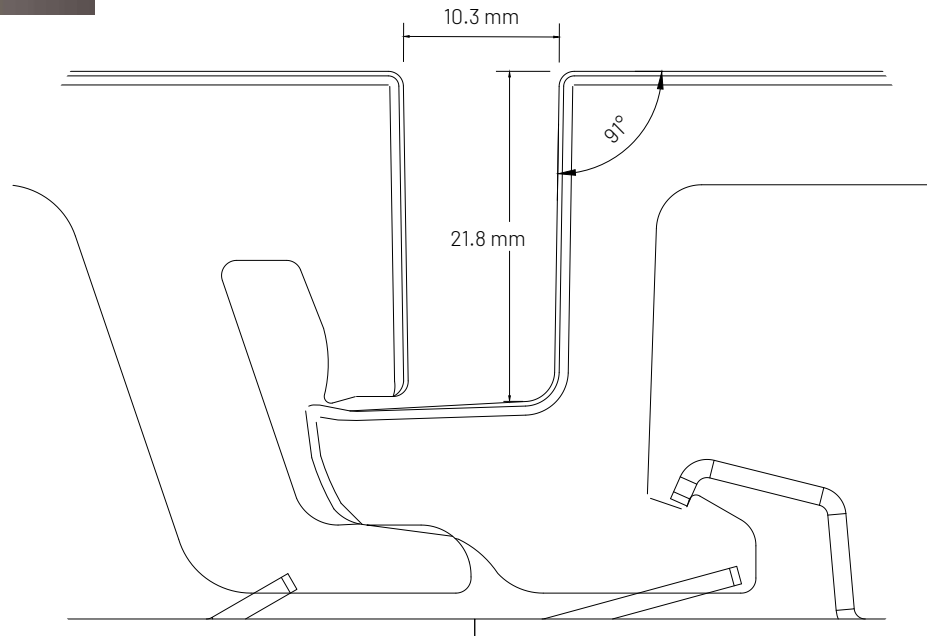

STTHM205 - Tongue and groove interaction

Scale 2:1

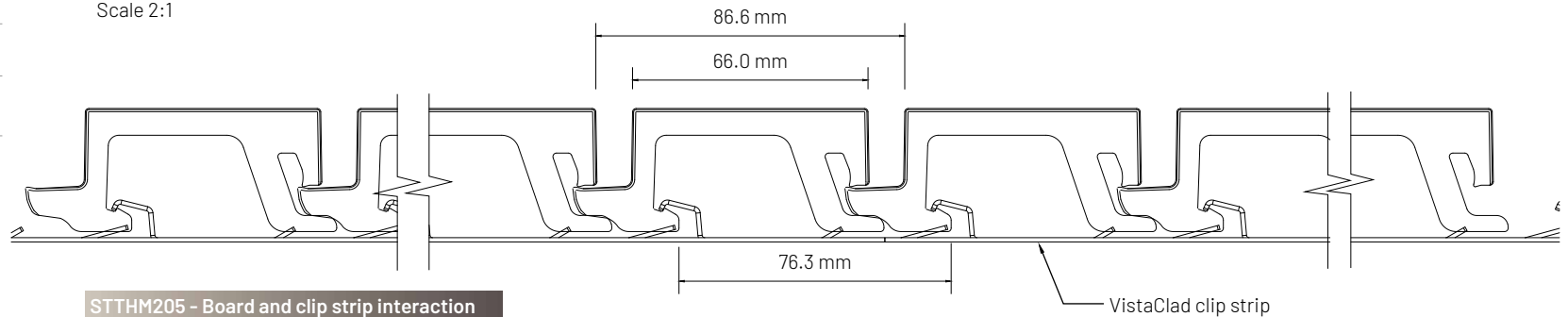

STTHM205 - Board and clip strip interaction

Scale 1:2

Appendix B

System component

Profile properties

Product code	Flat strip
Sectional area (mm ²)	48
Approximate mass (kg/m)	±0.4



Sectional properties

I _x (mm ⁴)	Section A	6	Section B	2.2
I _y (mm ⁴)		6 400		4 889
C _x (mm)		0.6		0.6
C _y (mm)		20		20
S _x (mm ³)		10		10
S _y (mm ³)		320		244

Drawing title

Cladding clip strip - Flat strip

File name

TDS - 2023-03-03 - Cladding

File details

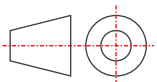

Drawing number	01
Date	March 3, 2023
Page	6 of 8
Scale	NTS

Unless otherwise specified all dimensions are in millimeters.

Issued for information. See supporting documentation for disclaimers and details.

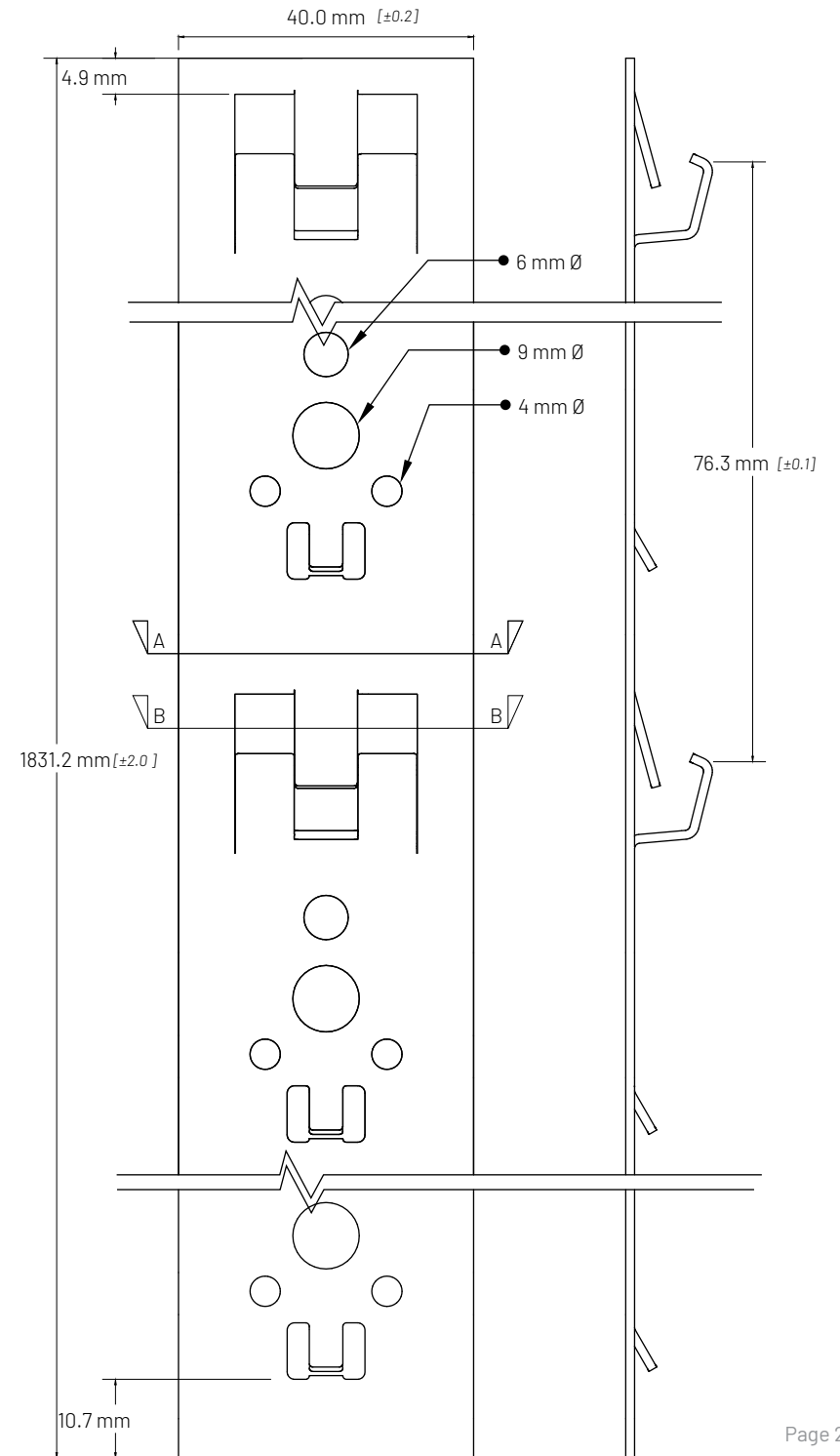
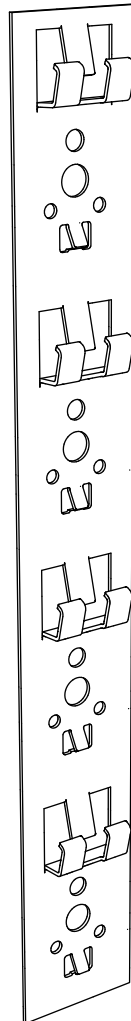
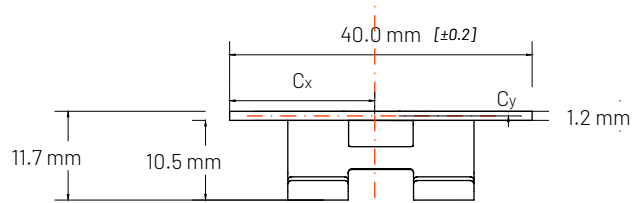

Profile properties

Product code	Channel
Sectional area (mm ²)	105
Approximate mass (kg/m)	±0.8

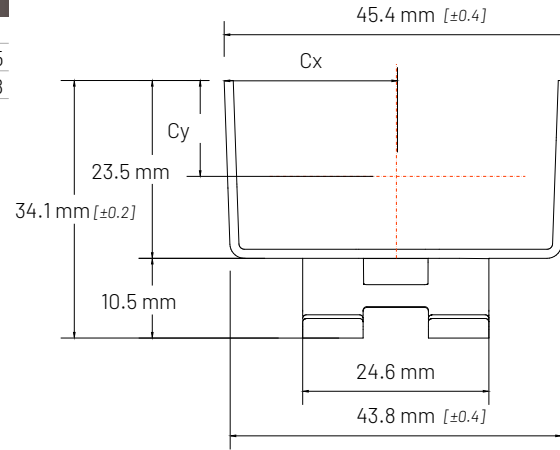

Sectional properties

I_x (mm ⁴)	Section A	5 820	Section B	3 775
I_y (mm ⁴)		33 006		21 334
C_x (mm)		22.7		22.7
C_y (mm)		16.9		16.0
S_x (mm ³)		345		235
S_y (mm ³)		1 455		950

Drawing title

Cladding clip strip - Channel

File name

TDS - 2023-03-03 - Cladding

File details

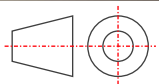

Drawing number	01
Date	March 3, 2023
Page	7 of 8
Scale	NTS

Unless otherwise specified all dimensions are in millimeters.

Issued for information. See supporting documentation for disclaimers and details.

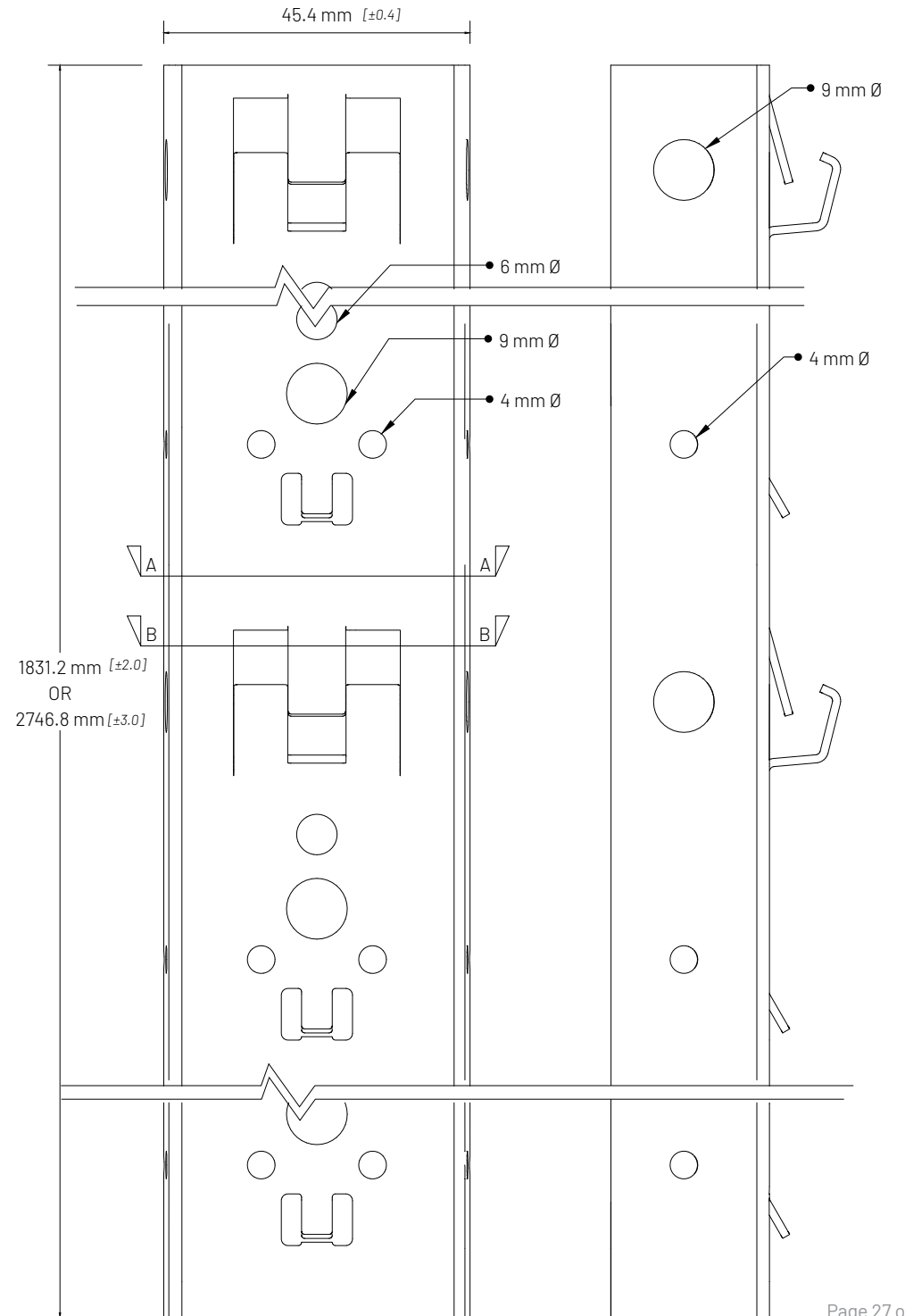
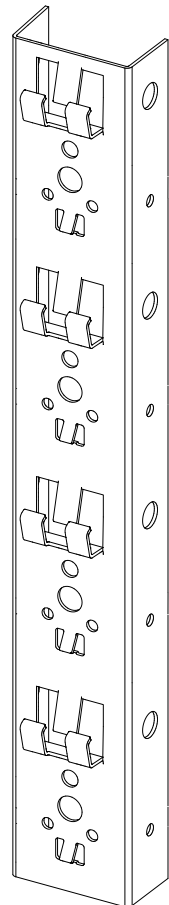

Profile properties

Product code
 Sectional area (mm²)
 Approximate mass (kg/m)



Sectional properties

I_x (mm ⁴)	Section A	17 166	Section B	9 446
I_y (mm ⁴)		87 585		50 452
C_x (mm)		42.7		42.7
C_y (mm)		12.8		11.8
S_x (mm ³)		1 338		802
S_y (mm ³)		2 050		1 180

Drawing title

Cladding clip strip - Top hat

File name

TDS - 2023-03-03 - Cladding

File details

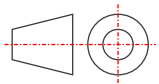

Drawing number	01
Date	March 3, 2023
Page	8 of 8
Scale	NTS

Unless otherwise specified all dimensions are in millimeters.

Issued for information. See supporting documentation for disclaimers and details.

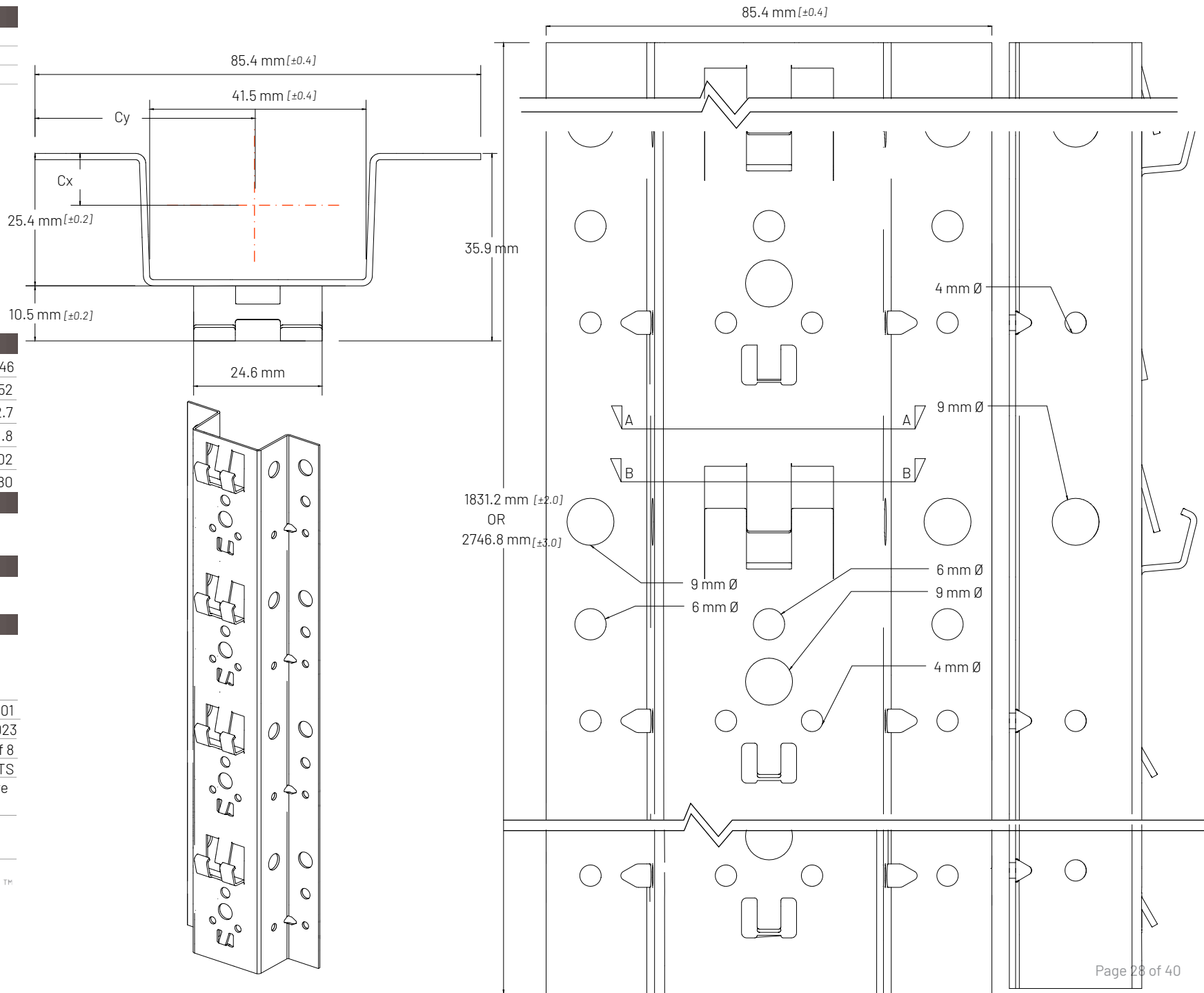

Profile properties

Product code
 Sectional area (mm²)
 Approximate mass (kg/m)



Sectional properties

I_x(mm⁴)
 I_y(mm⁴)
 C_x(mm)
 C_y(mm)
 S_x(mm³)
 S_y(mm³)

Drawing title

Cladding trim - Universal trim - top and bottom application

File name

TDS - 2023-03-03 - Cladding

File details

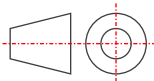

Drawing number 01
 Date March 3, 2023
 Page 9 of 8
 Scale NTS

Unless otherwise specified all dimensions are in millimeters.

Issued for information. See supporting documentation for disclaimers and details.

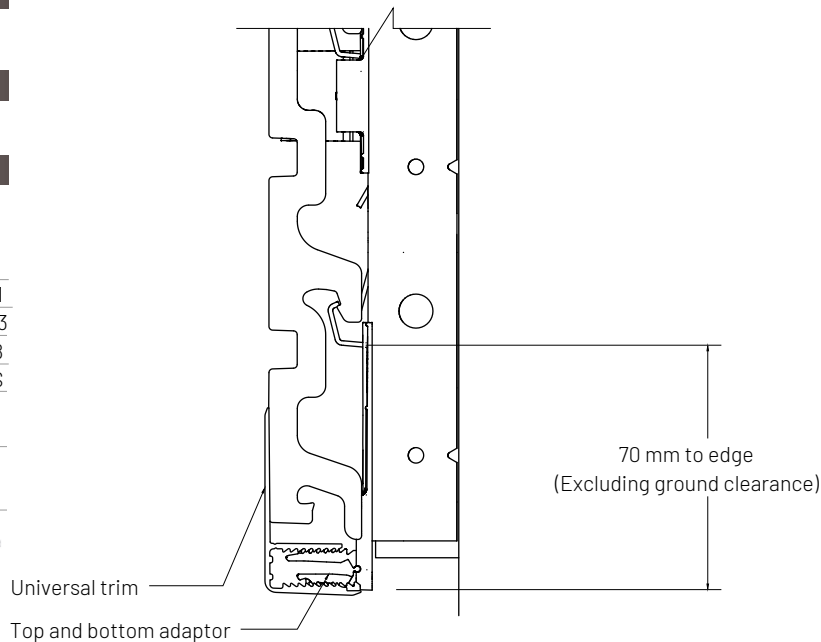
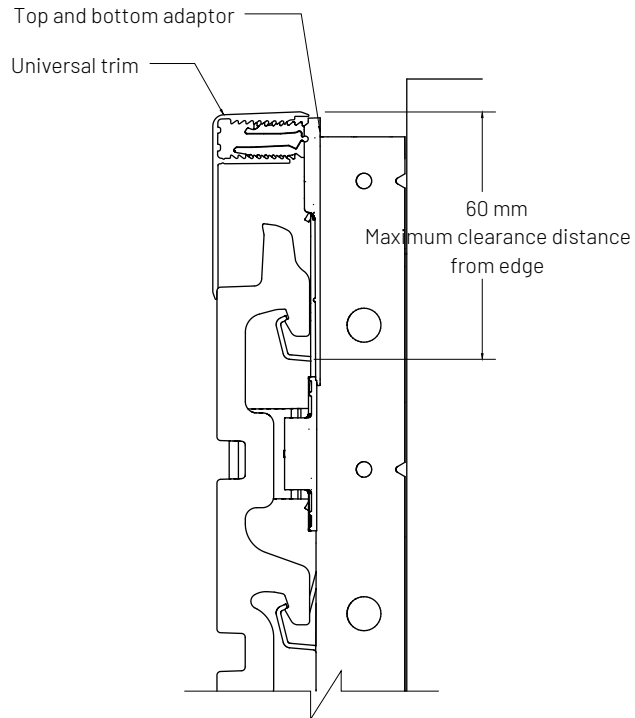

Top and bottom assemblies

Scale 1:1

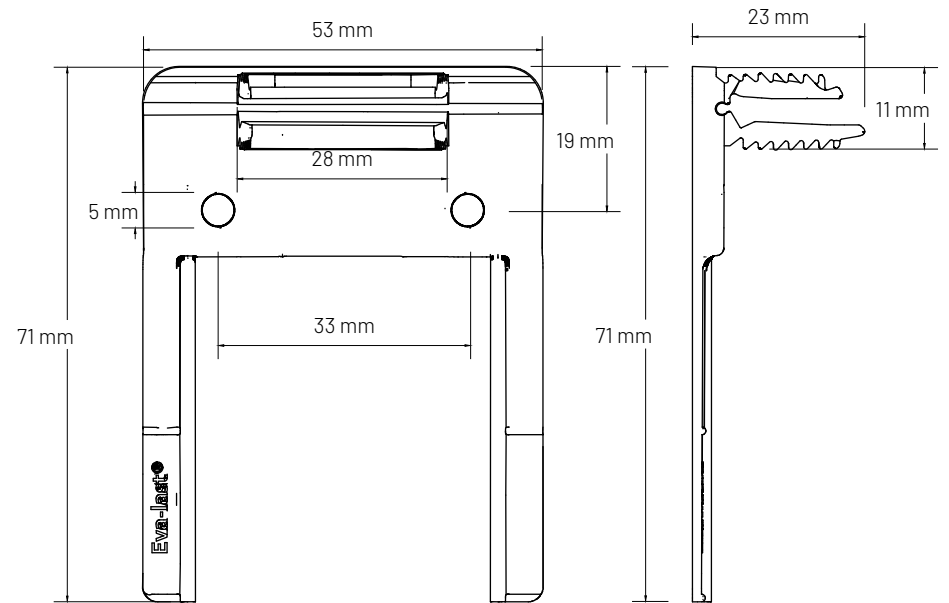

Nylon Top and bottom adaptor

Scale 1:1

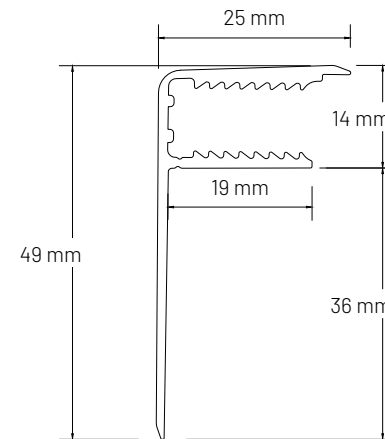

Aluminium universal trim profile

Scale 1:1

Profile properties

Product code
 Sectional area (mm²)
 Approximate mass (kg/m)

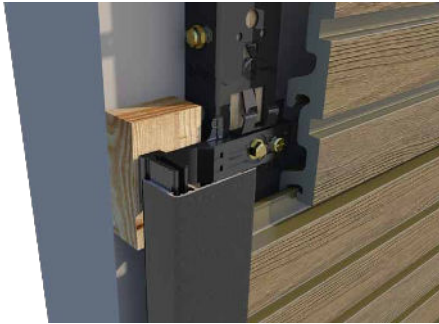

Sectional properties

I_x (mm⁴)
 I_y (mm⁴)
 C_x (mm)
 C_y (mm)
 S_x (mm³)
 S_y (mm³)

Drawing title

Cladding trim - Universal trim. edge application

File name

TDS - 2023-03-03 - Cladding

File details

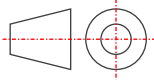

Drawing number 01
 Date March 3, 2023
 Page 10 of 8
 Scale NTS

Unless otherwise specified all dimensions are in millimeters.

Issued for information. See supporting documentation for disclaimers and details.



Side adaptor

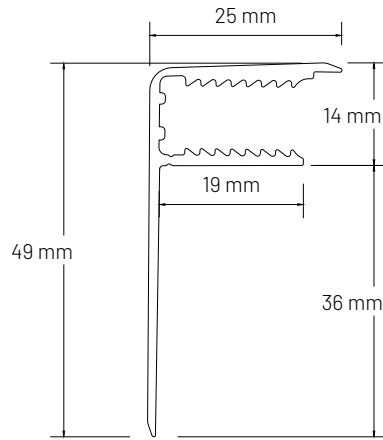

Aluminium universal trim profile

Scale 1:1

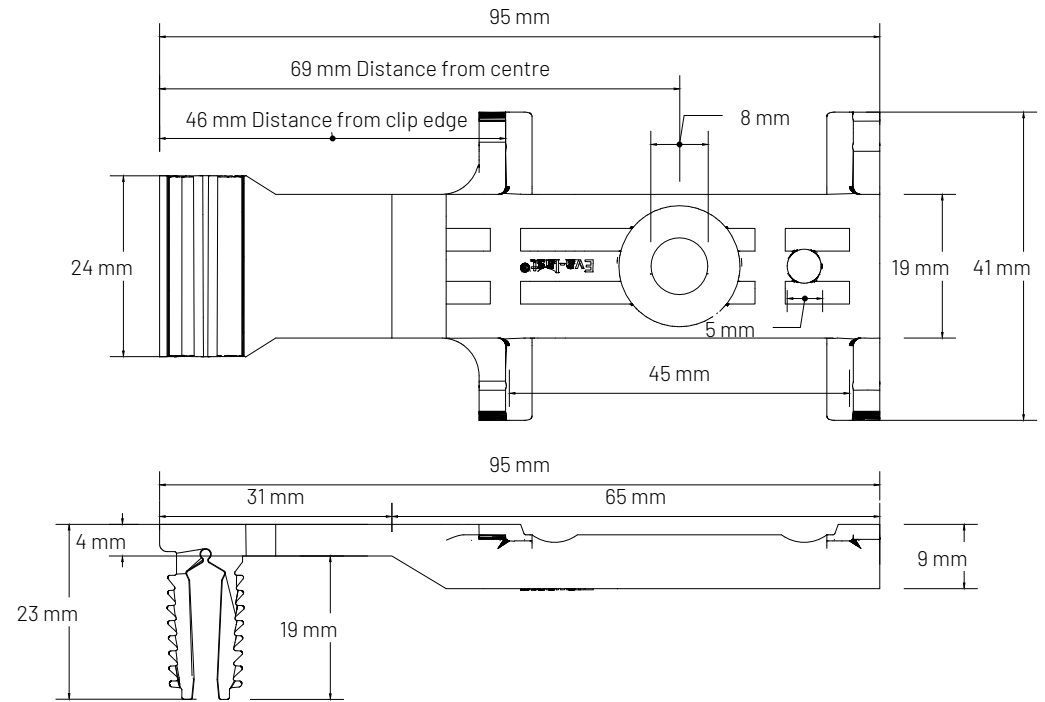

Nylon Side adaptor

Scale 1:1

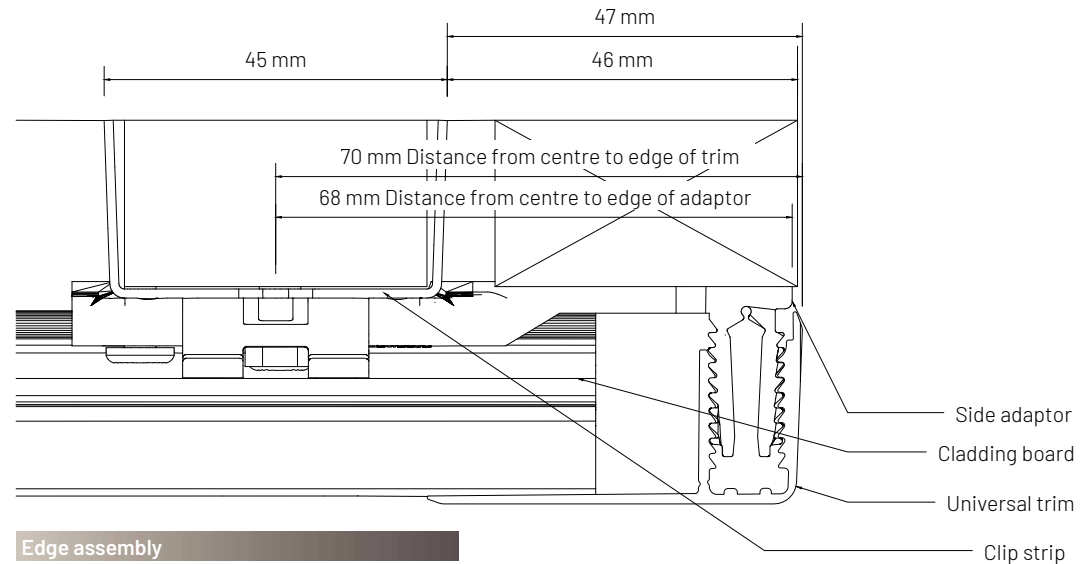

Edge assembly

Scale 1:1

Profile properties

Product code

Sectional area (mm²)

Approximate mass (kg/m)

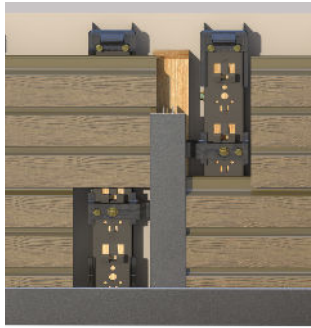

Sectional properties

I_x(mm⁴)

I_y(mm⁴)

C_x(mm)

C_y(mm)

S_x(mm³)

S_y(mm³)

Drawing title

Cladding trim - T trim (Butt join) application

File name

TDS - 2023-03-03 - Cladding

File details

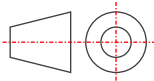

Drawing number 01

Date March 3, 2023

Page 11 of 8

Scale NTS

Unless otherwise specified all dimensions are in millimeters.

Issued for information. See supporting documentation for disclaimers and details.

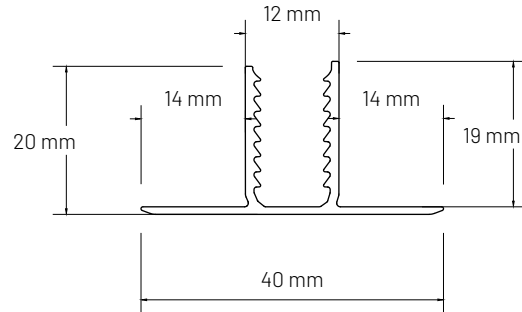

Aluminium T trim profile

Scale 1:1

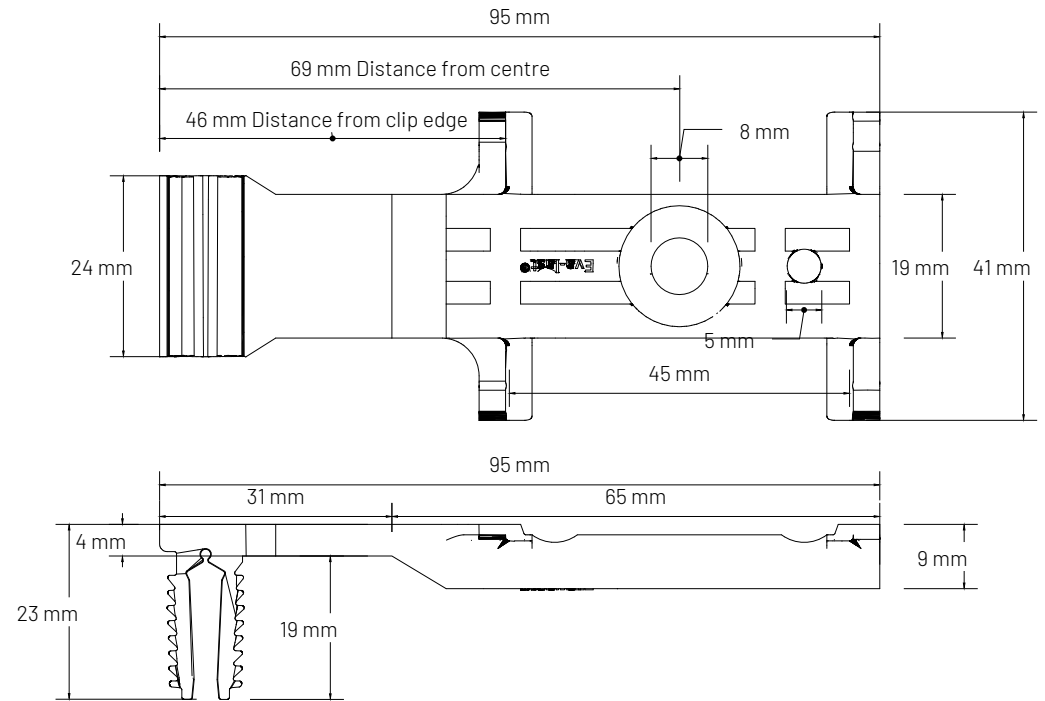

Nylon Side adaptor

Scale 1:1

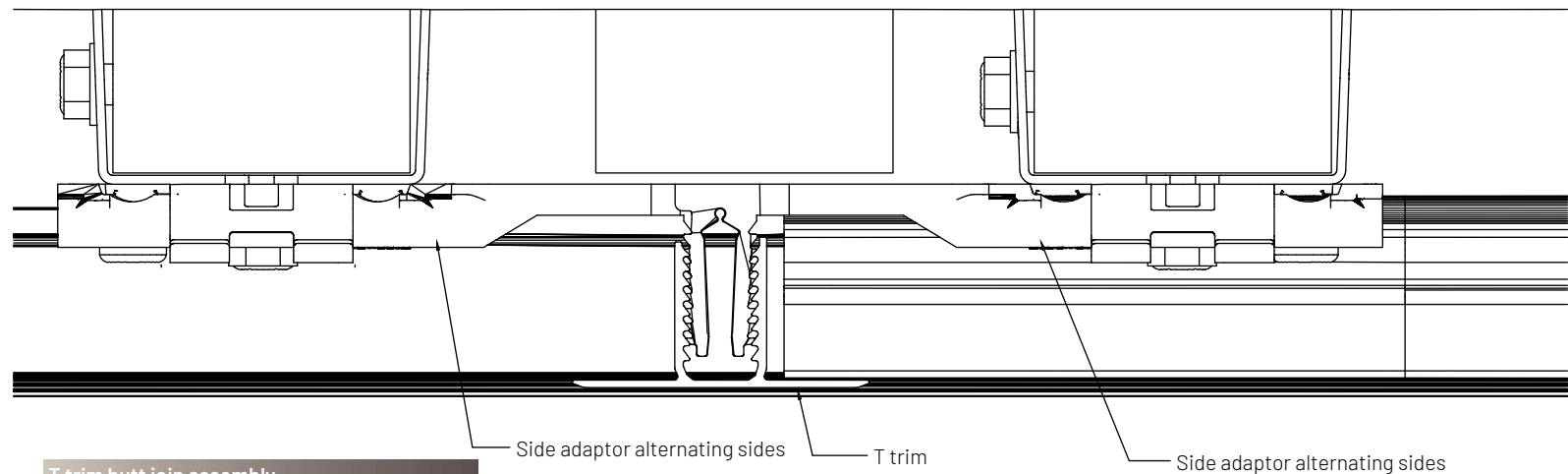

T trim butt join assembly

Scale 1:1

Profile properties

Product code
 Sectional area (mm²)
 Approximate mass (kg/m)



Sectional properties

I_x (mm⁴)
 I_y (mm⁴)
 C_x (mm)
 C_y (mm)
 S_x (mm³)
 S_y (mm³)

Drawing title

Cladding trim - U trim (Butt join) application

File name

TDS - 2023-03-03 - Cladding

File details

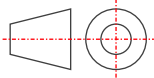

Drawing number 01
 Date March 3, 2023
 Page 12 of 8
 Scale NTS

Unless otherwise specified all dimensions are in millimeters.

Issued for information. See supporting documentation for disclaimers and details.

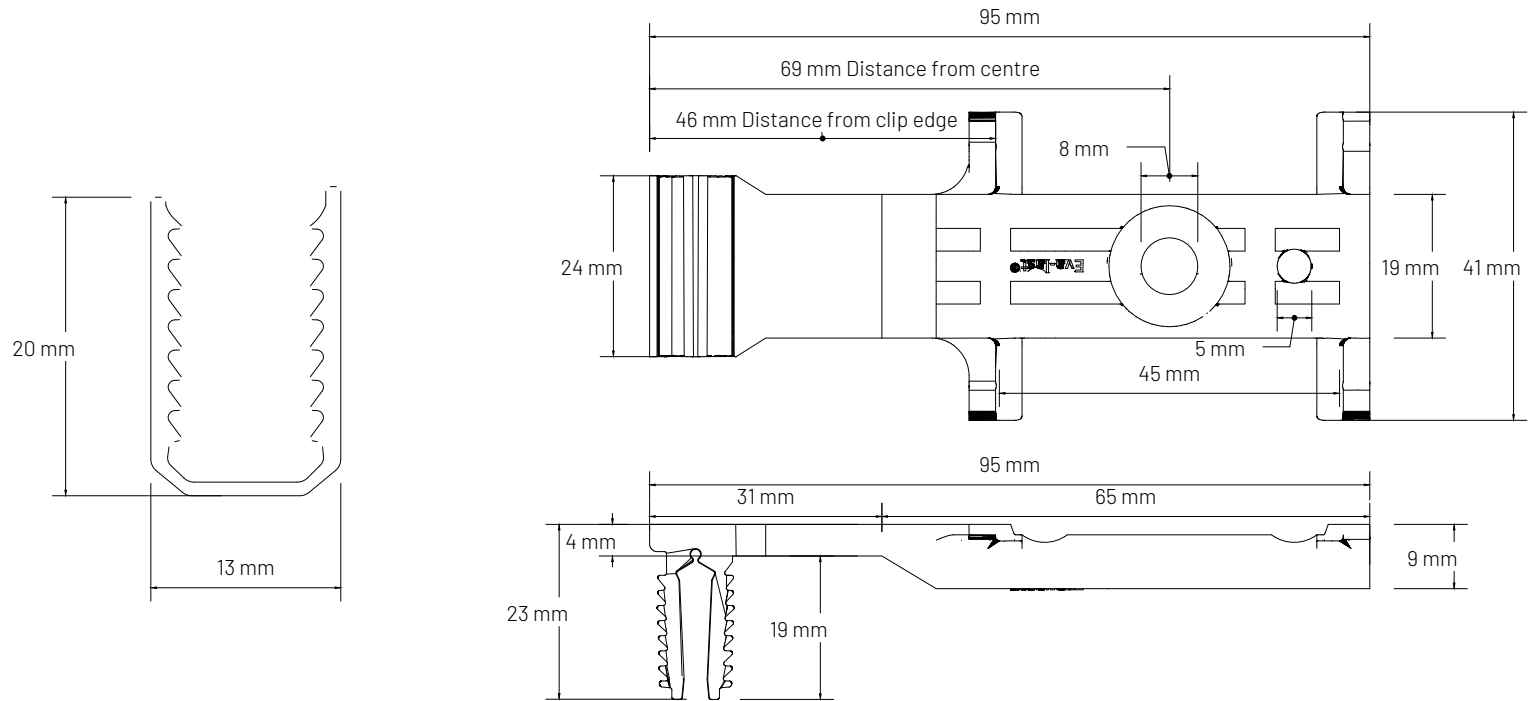

Aluminium U trim

Scale 2:1

Nylon Side adaptor

Scale 1:1

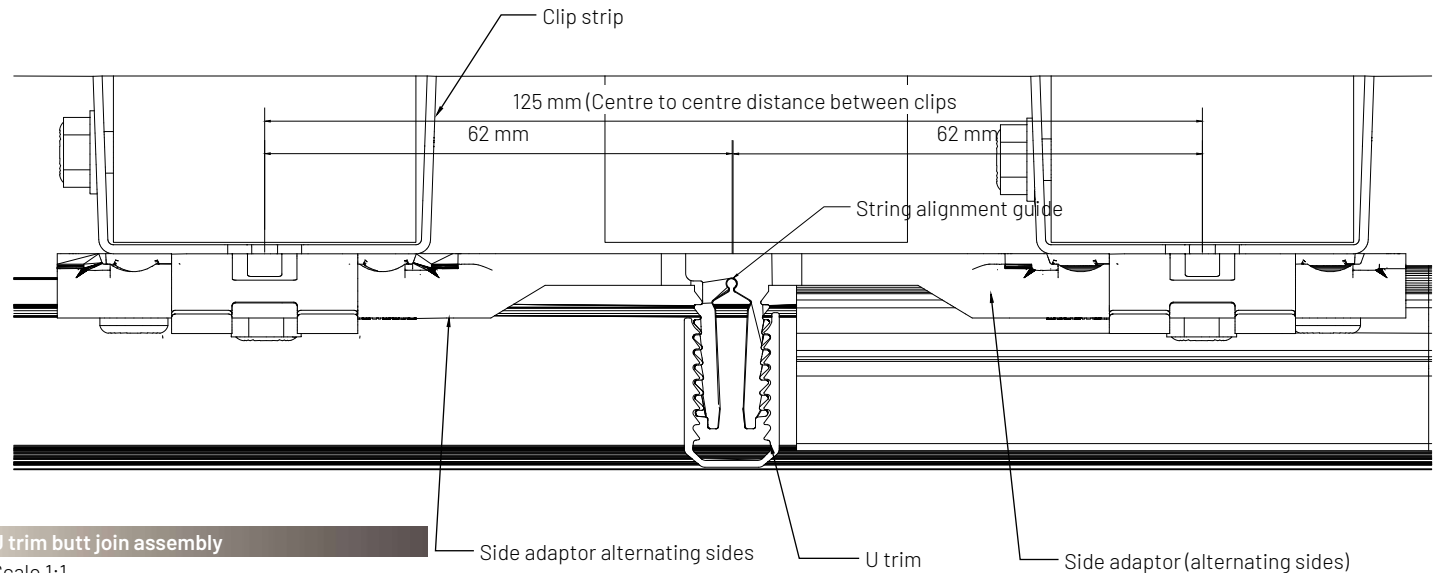

U trim butt join assembly

Scale 1:1

Profile properties

Product code
Sectional area (mm²)
Approximate mass (kg/m)



Sectional properties

I_x(mm⁴)
I_y(mm⁴)
C_x(mm)
C_y(mm)
S_x(mm³)
S_y(mm³)

Drawing title

Cladding trim - Internal corner application

File name

TDS - 2023-03-03 - Cladding

File details

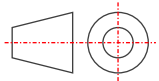

Drawing number 01
Date March 3, 2023
Page 13 of 8
Scale NTS

Unless otherwise specified all dimensions are in millimeters.

Issued for information. See supporting documentation for disclaimers and details.

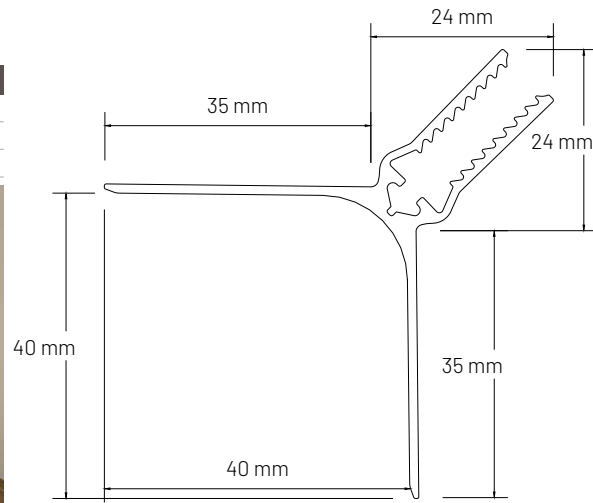

Aluminium Internal corner trim profile

Scale 1:1

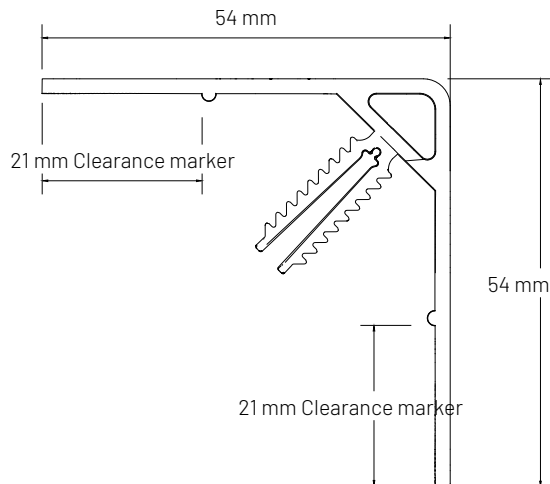
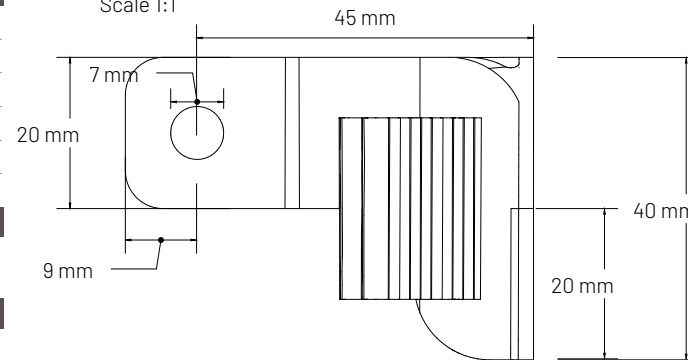

Nylon Internal corner adaptor

Scale 1:1

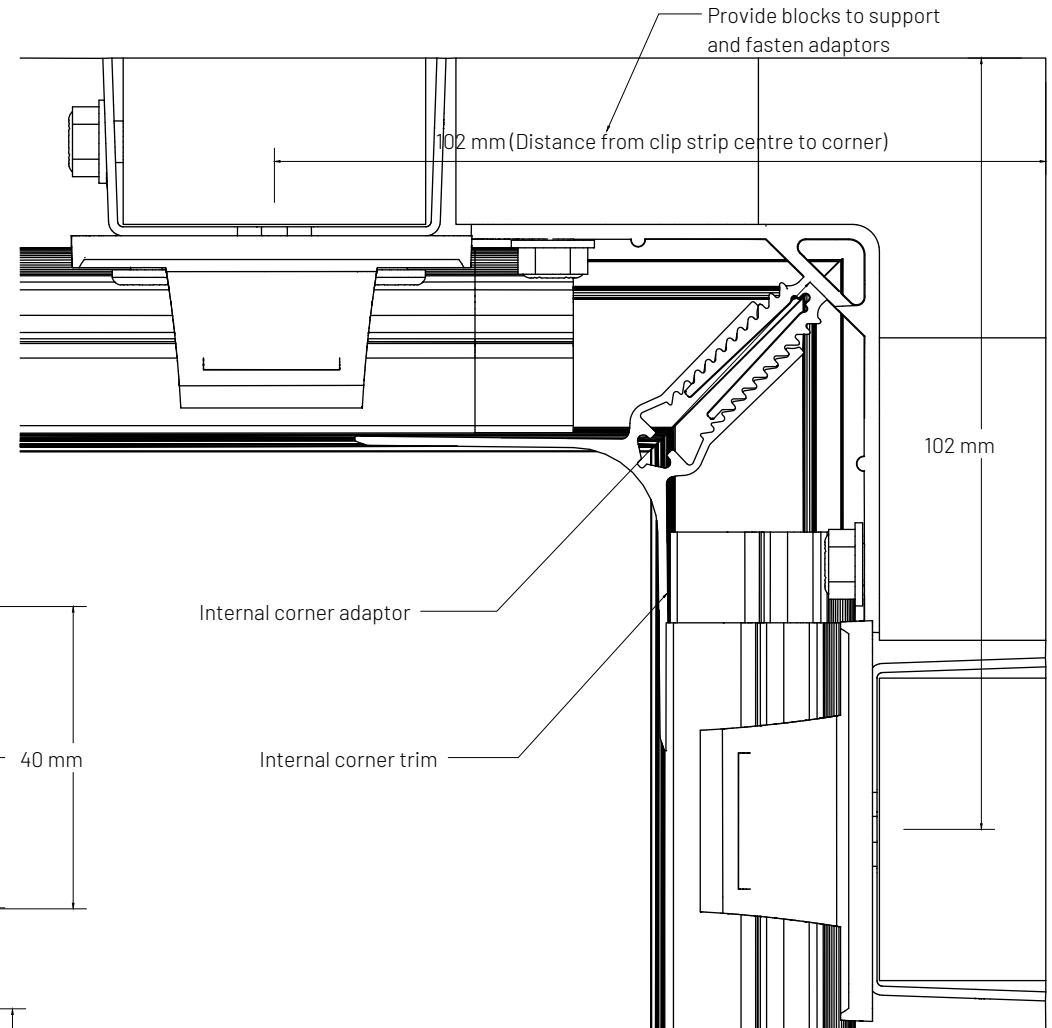

Internal corner assembly detail

Scale 1:1

Profile properties

Product code
 Sectional area (mm²)
 Approximate mass (kg/m)



Sectional properties

I_x (mm⁴)
 I_y (mm⁴)
 C_x (mm)
 C_y (mm)
 S_x (mm³)
 S_y (mm³)

Drawing title

Cladding trim - External corner application

File name

TDS - 2023-03-03 - Cladding

File details

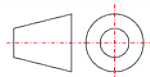

Drawing number 01
 Date March 3, 2023
 Page 14 of 8
 Scale NTS

Unless otherwise specified all dimensions are in millimeters.

Issued for information. See supporting documentation for disclaimers and details.

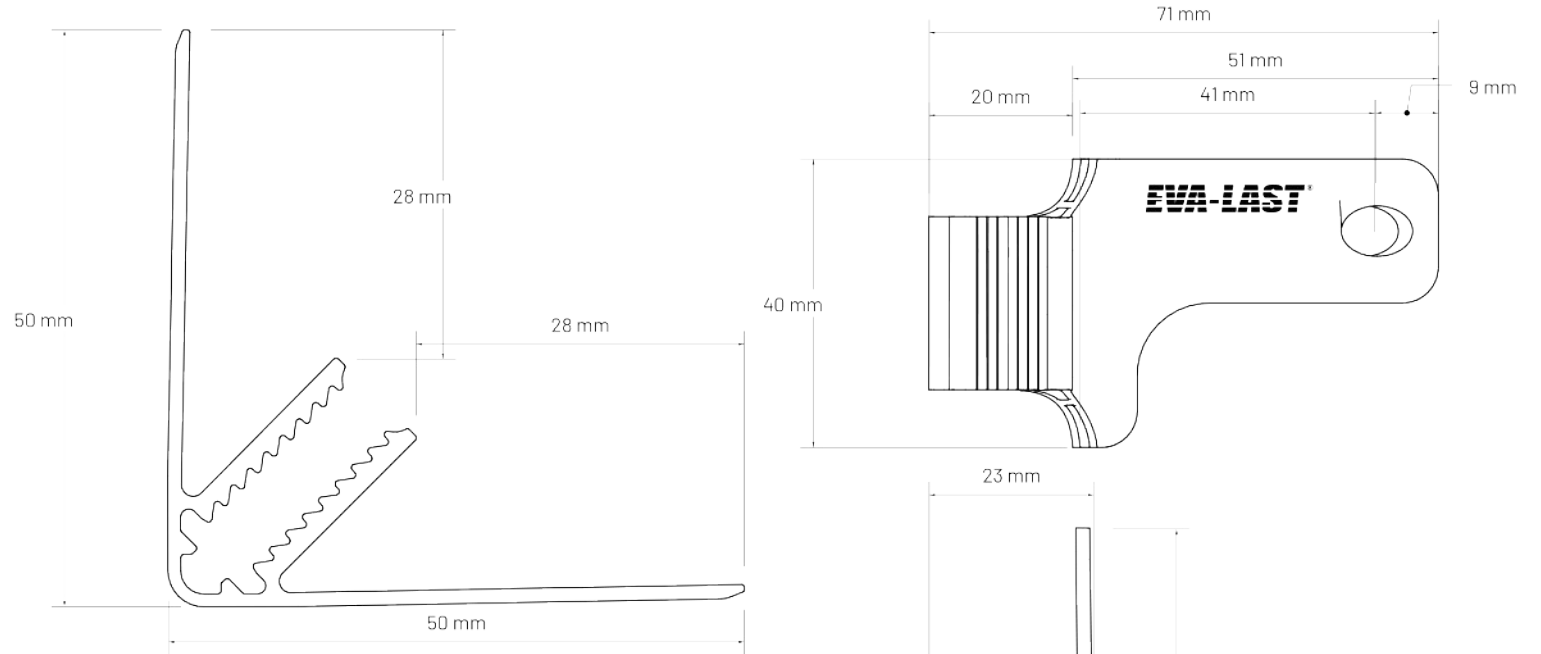

Aluminium External corner trim profile
 Scale 1:1

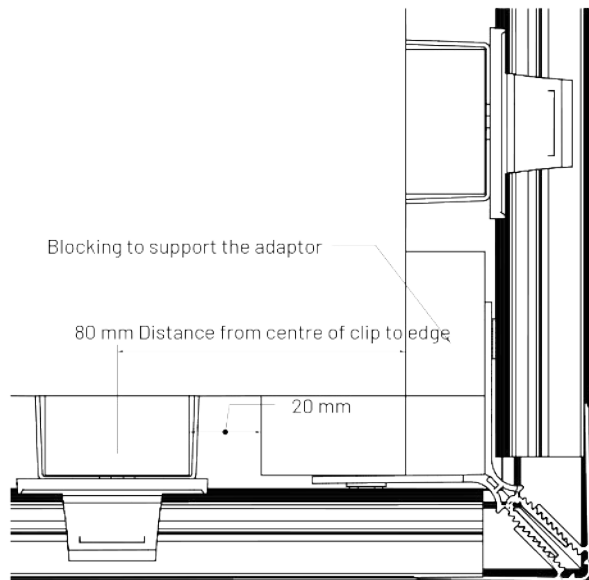

External corner assembly detail
 Scale 1:1

Nylon External corner adaptor
 Scale 1:1

External corner trim
 External corner adaptor

Appendix C

Material compatibility

The following information captures the typical performance of ASA (the primary component of Apex cap) when introduced to common substances. This information has been collected from an online source and is not exhaustive. It is recommended to check for any incompatibility on a sample before applying any substances to the product. It is prudent to consider usual cleaning products, pool additives as well as oils and saps from local vegetation in this assessment.

Symbol legend

The symbols and abbreviations used have the following meanings:

- + = resistant over a period of months to years.
- 0 = limited resistance: some swelling, solvation or environmental stress cracking is possible.
- = not resistant: severe swelling, decomposition, solvation or environmental stress cracking.
- soln. = saturated aqueous solution.

Resistance definition

Good resistance: Water, aqueous salt solutions, detergent solutions, dilute acids, and alkalis.

Limited resistance: Alcohols, aliphatic hydrocarbons, oils, and fats.

Not resistant: Concentrated mineral acids, aromatic and/or halogenated hydrocarbons, esters, ethers, ketones.

Solvents: Examples are methyl ethyl ketone, tetrahydrofuran, toluene, dimethyl-formamide.

Source data:

BASF – Chemical resistance of styrene co-polymers - www.basf.de/plastics

Test substance	20 °C	50 °C
Acetamide	+	+
Acetic acid (100%)	-	-
Acetic acid (25%)	+	+
Acetic acid (50%)	+	0
Acetone	-	-
Acetophenone	-	-
Acetylsalicylic acid (soln.)	+	+
Allyl alcohol	-	-
Allyl mustard oil	-	-
Almond, bitter, oil of	+	0
Almond, oil of	+	+
Alum (soln.)	+	+
Aluminium chloride (soln.)	+	+
Aluminium sulphate (soln.)	+	+
Ammonia, aqueous (25%)	+	+
Ammonium carbonate (soln.)	+	+
Ammonium chloride (soln.)	+	+
Ammonium molybdate (soln.)	+	+
Ammonium nitrate (soln.)	+	+
Ammonium rhodanide (soln.)	+	+

Ammonium sulphate (soln.)	+	+
Amyl acetate	-	-
Amyl acetate	-	-
Amyl alcohol	+	0
Amyl cinnamaldehyde	-	-
Amyl mercaptan	-	-
Aniline	-	-
Anise, oil of	-	-
Aniseed	+	+
Apple juice	+	+
Aqua regia	0	-
Atropine sulphate	+	+
Barium bromide (soln.)	+	+
Barium carbonate (soln.)	+	+
Barium chloride (soln.)	+	+
Beef tallow	+	+
Benzaldehyde	-	-
Benzene	-	-
Benzoic acid	+	+
Benzyl acetate	-	-
Benzyl acetate	-	-

Chlorobenzene	-	-
Chloroform	-	-
Chlorosulfonic acid	-	-
Chromic acid (soln.)	0	0
Chromosulfuric acid	0	0
Cinnamic aldehyde	-	-
Cinnamon (ground)	+	+
Cinammon (sticks)	+	+
Citric acid (soln.)	+	+
Citronella, oil of	-	-
Cloves	-	-
Cloves, oil of	-	-
Cocoa butter	+	+
Coconut oil	+	+
Cod-liver oil	+	+
Coffee (ground)	+	+
Coffee extract	+	+
Copper sulphate (soln.)	+	+
Corn oil	+	+
Cottonseed oil	+	+
Cresol (para)	0	-
Curry	+	+
Cyclohexane	+	0
Cyclohexanol	+	0
Cyclohexanone	-	-
Dairy products	+	+
Dehydroacetic acid	+	+
Dekalin (R)	0	0
Diacetone alcohol	-	-
Dibutyl phthalate	-	-
Dichlorobenzene	-	-
Diesel oil	+	+
Diethanolamine	+	+
Diethyl ether	-	-
Diethyl hexyl phthalate	+	0
Diethyl ketone	+	+
Diethyl phthalate	-	-
Diethylene glycol	+	+

Benzyl alcohol	-	-
Bismuth chloride (soln.)	+	+
Bismuth subnitrate (soln.)	+	+
Bone oil	+	+
Borax (soln.)	+	+
Boric acid (soln.)	+	+
Brake fluid (ATE)	-	-
Brandy	+	+
Bromine (liquid)	-	-
Butane	+	+
Butter	+	+
Butyl acetate	-	-
Butyl acetate	-	-
Butyric acid	-	-
Cadmium bromide (soln.)	+	+
Caffeine (soln.)	+	+
Calcium bromide (soln.)	+	+
Calcium chloride (soln.)	+	+
Calcium hypochlorite (solid)	+	+
Calcium hypochlorite (soln.)	+	+
Calcium oxide	+	+
Camphor	+	+
Caraway seed (ground)	+	+
Carbazole	+	+
Carbon dioxide	+	+
Carbon sulphide	-	-
Cardamom	+	+
Carnauba wax	+	+
Carrot juice	+	+
Castor oil	+	+
Cellosolve (methyl-, ethyl-, propyl-, butyl-)	-	-
Cesium bromide (soln.)	+	+
Cetyl alcohol	+	+
Chamomile extract	+	+
Chlorinated lime	+	+
Chlorine (liquid or gaseous)	-	-
Chlorine water	0	0
Chloroacetic acid	0	-

Diisodecyl phthalate	0	0
Dimethyl diglycol phthalate	0	0
Dimethyl phthalate	-	-
Dimethylformamide	-	-
Dinonyl phthalate	0	0
Dioxane (1,4 dioxane)	-	-
Diphenyl ether	-	-
Diphenylamine	-	-
Ethanol (40%)	+	+
Ethanol (95%)	+	0
Ether (Diethyl ether)	-	-
Ethyl acetate	-	-
Ethyl benzene	-	-
Ethyl benzoate	-	-
Ethyl chloride	-	-
Ethylene chloride	-	-
Ethylene glycol	+	+
Eucalyptus, oil of	0	0
Fertilizer salts	+	+
Formaldehyde (30%)	+	0
Formic acid (40%)	+	0
Formic acid (85%)	0	0
Frigen/Freon 11 (Monofluoro- trichloromethane)	0	0
Frigen/Freon 113 (Trifluoro-trichloroethane)	0	0
Frigen/Freon 114 (Tetrafluoro-dichloroethane)	0	0
Frigen/Freon 12 (Difluoro-dichloromethane)	0	0
Frigen/Freon 21 (Monofluoro-dichloromethane)	-	-
Frigen/Freon 22 (Difluoro-monochloro-methane)	-	-
Furfural	-	-
Furfuryl alcohol	0	-
Gallic acid	+	+
Garlic (powder)	+	+
Gasoline (Premium unleaded)	0	-
Gasoline (Standard unleaded)	0	0
Ginger (ground)	0	0

Glucose (30%)	+	+
Glycerine	+	+
Grapefruit juice	+	+
Gravy	+	+
Heating oil	+	+
Heptane	0	0
Heptyl alcohol	+	0
Hexachlorobenzene	+	+
Hexane	0	0
Hexanediol	+	+
Hexanol	+	0
Honey	+	+
Horse radish	+	+
Household detergent (soln.)	+	+
Hydrochloric acid (15%)	+	0
Hydrochloric acid (conc.)	+	0
Hydrofluoric acid (40%)	0	0
Hydrogen peroxide (3%)	+	+
Hydrogen peroxide (30%)	+	+
Hydrogen sulphide	+	+
Hydroquinone (soln.)	+	0
Hydroxyacetone	0	0
Ink, writing	+	+
Iodine, tincture of	0	-
Iron (II) chloride (solid)	+	+
Iron (II) chloride (soln.)	+	+
Iron (II) sulphate (solid)	+	+
Iron (III) chloride (soln.)	+	+
Iron ammonium sulphate	+	+
Iron nitrate (soln.)	+	+
Isoamyl alcohol	+	0
Isobutanol	0	-
Isooctane	+	+
Isooctane	+	+
Isopropanol	+	-
Isopropyl acetate	-	-
Lactic acid (10%)	+	+
Lactic acid (80%)	+	+

Lactose (soln.)	+	+
Lanolin +	+	+
Laurel (ground)	+	+
Lauryl alcohol	+	+
Lead acetate (soln.)	+	+
Lead nitrate (soln.)	+	+
Lead stearate	+	+
Lead sulphate (soln.)	+	+
Lemon grass, oil of	-	-
Lemon juice	+	+
Lemon, oil of	0	0
Ligroin	+	+
Lime water	+	+
Linseed oil	+	+
Mace (ground)	+	0
Magnesium bromide	+	+
Magnesium carbonate	+	+
Magnesium chloride (soln.)	+	+
Magnesium sulphate (soln.)	+	+
Maize oil	+	+
Malic acid (10%)	+	+
Mandarin orange, oil of	0	0
Margarine	+	+
Marjoram (ground)	+	+
Marmalade	+	+
Mayonnaise	+	+
Menthol (10% in ethanol)	0	0
Mercury	+	+
Mercury chloride (soln.)	+	+
Mesityl oxide	-	-
Methanol	0	-
Methyl acetate	-	-
Methyl butanol	+	0
Methyl chloride	-	-
Methyl cyclohexane	+	+
Methyl ethyl ketone	-	-
Methyl isobutyl ketone	-	-
Methyl isopropyl ketone	-	-

Methyl propyl ketone	-	-
Methyl salicylate	-	-
Methylene chloride	-	-
Methylene chlorobromide	-	-
Milk	+	+
Milk powder	+	+
Milk powder (moist)	+	+
Monoamyl phthalate	-	-
Motor oil (automotive)	+	+
Mustard	+	+
n-Butanol	+	0
n-Nonanol	+	+
n-Octanol	+	+
n-Propanol	+	0
Naphthalene (solid)	+	-
Naphthalene (soln. in ethanol)	0	-
Naphthol (beta)(soln. in ethanol)	0	-
Nickel sulphate (soln.)	+	+
Nitric acid (30%)	+	0
Nitric acid (conc.)	-	-
Nitrobenzene	-	-
Nutmeg, dark (ground)	0	0
Nutmeg, light (ground)	+	0
Nutmeg, oil of	0	-
Oleic acid	+	0
Olive oil	+	+
Onion (powder)	+	+
Orange juice	+	+
Orange, oil of	0	0
Oxalic acid (soln.)	+	+
Oxymethylfurfural	-	-
Ozone (<0,5 ppm)	+	+
Palamoll 644 und 646 (polyesters based on adipic acid, BASF)	-	-
Palm oil	+	+
Palmitic acid	+	+
Paprika (ground)	+	+
Paraffin oil	+	+
Peanut oil	+	+

Peanut oil	+	+
Pectin (soln.)	+	+
Penicillin	+	+
Pentane	0	0
Pepper (black or white, ground)	+	0
Peppermint, oil of	-	-
Perchloroethylene (Tetrachloroethylene)	0	0
Petroleum ether	0	0
Petroleum jelly	0	-
Petroleum jelly	+	+
Phenacetin	+	+
Phenol	-	-
Phenylethanol	-	-
Phosphoric acid (1%)	+	+
Phosphoric acid (30%)	+	+
Phosphoric acid (85%)	+	+
Phthalic acid (soln.) Pimento (ground)	+	+
Pine needles, oil of	0	-
Pineapple juice	+	+
Plastomoll DOA (di-(2-ethyl-hexyl) adipate, BASF)	0	0
Pork lard	+	+
Potassium aluminium sulphate (soln.)	+	+
Potassium bisulfate	+	+
Potassium bromates (soln.)	+	+
Potassium bromide (soln.)	+	+
Potassium chloride (soln.)	+	+
Potassium chromate (soln.)	+	+
Potassium dichromate (soln.)	+	0
Potassium ferricyanide	+	+
Potassium fluoride (soln.)	+	+
Potassium hydroxide (10%)	+	+
Potassium hydroxide (50%)	+	+
Potassium hydroxide (concentrated soln.)	+	0
Potassium iodate (soln.)	+	+
Potassium iodide (soln.)	+	+
Potassium nitrate (soln.)	+	+
Potassium permanganate (soln.)	+	0

Potassium persulfate (soln.)	+	+
Potassium sulphate (soln.)	+	+
Potassium sulphide (soln.)	+	+
Prontosil	+	+
Propane (liquid)	+	+
Propane (liquid) chloride	-	-
Propane glycol	+	+
Propylene glycol methyl ether	-	-
Propylene oxide	-	-
Pyridine	-	-
Pyrogallol (soln.)	+	0
Resorcin (soln.)	0	0
Rongalite (soln.)	+	+
Roses, oil of	0	0
Rum	+	+
Rum essence	+	+
Salicylic acid (soln.)	+	+
Salt, common (dry)	+	+
Sandalwood, oil of	-	-
Sassafras oil	-	-
Sea water	+	+
Sebacic acid dibutyl ester	-	-
Silicone fluid	+	+
Silver nitrate (soln.)	+	+
Sodium acetate (soln.)	+	+
Sodium benzoate (soln.)	+	+
Sodium bicarbonate (soln.)	+	+
Sodium bisulfite (soln.)	+	+
Sodium borate (soln.)	+	+
Sodium bromate (soln.)	+	+
Sodium bromide (soln.)	+	+
Sodium carbonate (soln.)	+	+
Sodium chloride (dry)	+	+
Sodium chloride (soln.)	+	+
Sodium chromate (soln.)	+	+
Sodium fluoride (soln.)	+	+
Sodium hydrogen sulfite	+	+
Sodium hydroxide (50%)	+	+
Sodium hypochlorite (soln. with 12% Cl)	+	+